

P-11976

21400

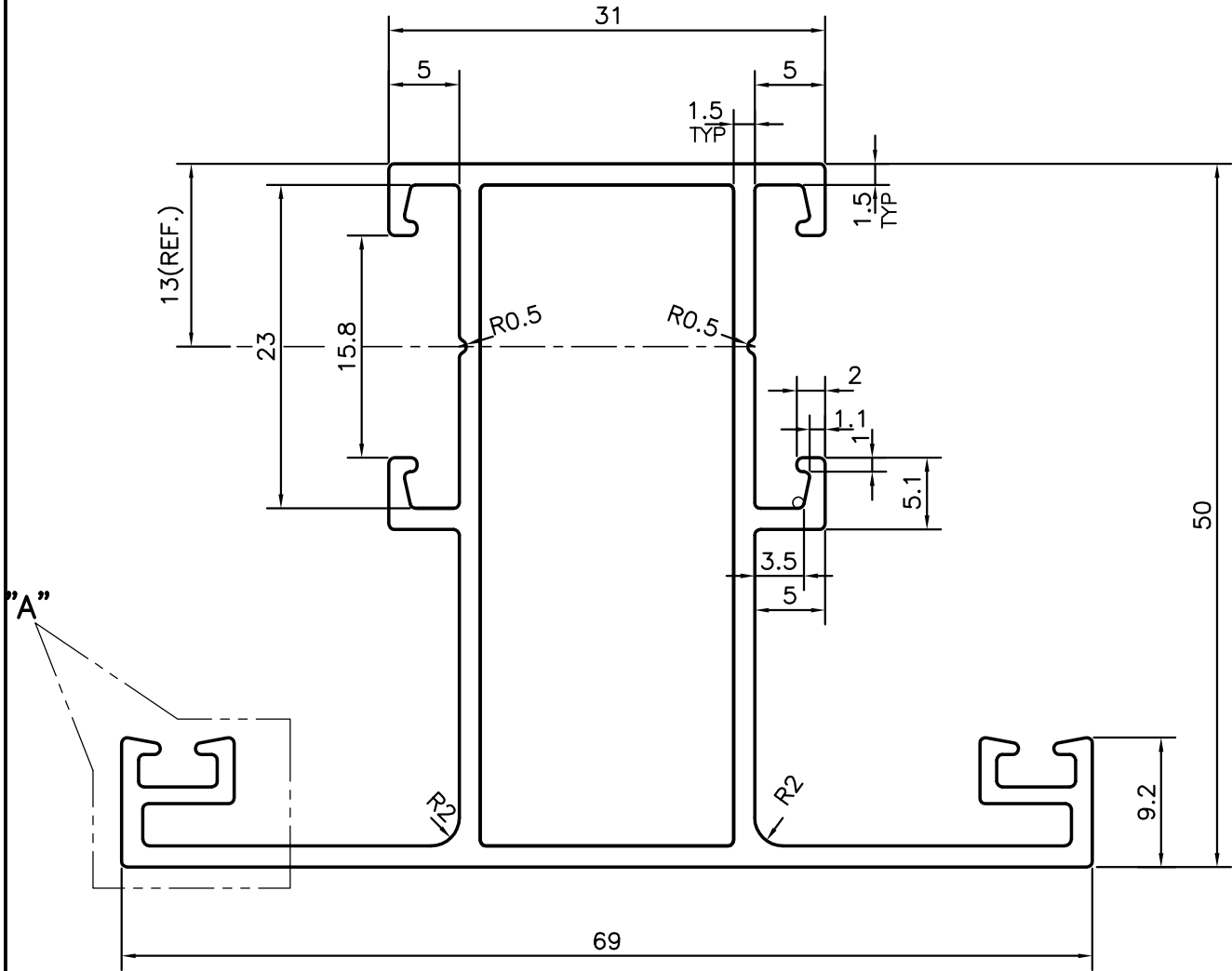
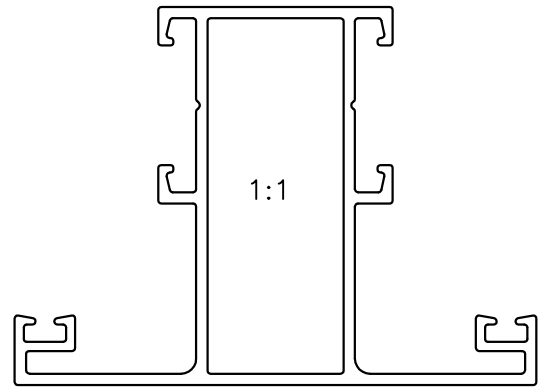
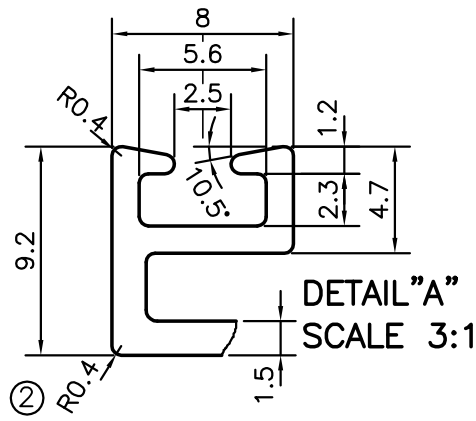

ISSUE:-2

RADIUS CHANGED FROM RADIUS 2 TO 0.4 RADIUS

WEIGHT ALSO CHANGED FROM 1.018 kg/M TO 1.023 kg/M



SYMBOL OF QUALITY
AN ISO 9001 COMPANY

JINDAL ALUMINIUM LTD.
BANGALORE-560073 (INDIA)

	NAME	DATE
DRAWN	J.P.KAUSHIK	14-11-2012
CHECKED		
APPROVED	S.S.GARG	20-11-2012

1. ALL DIMENSIONS ARE IN mm.
2. ROUND OFF ALL SHARP CORNERS WITH 0.40 mm.
3. TOLERANCES WILL BE AS PER, BS:EN-755-9 UNLESS OTHERWISE SPECIFIED

SCALE	2:1
AREA mm ²	378.773
PERIMETER mm.	383.415
WEIGHT kg/m	1.023

PARTY'S NAME	GENERAL CATEGORY, BANGALORE MARKET	DRAWING No.	P-11976	SECTION No.	-
PARTY'S DRAWING No.	6202 69x50		21400		21400(ISSUE-2)
ALLOY & TEMPER	63400 WP				
DESCRIPTION	WINDOW SECTION				