

P-12407

21407

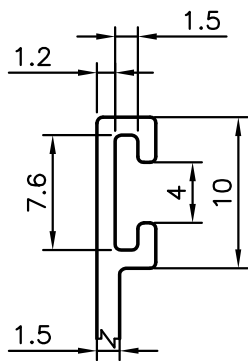

A (2:1)

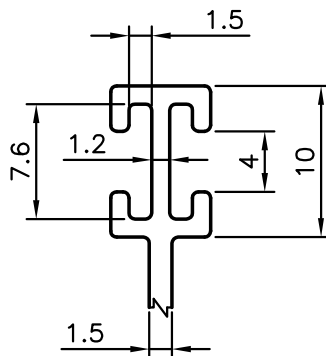

B (2:1)

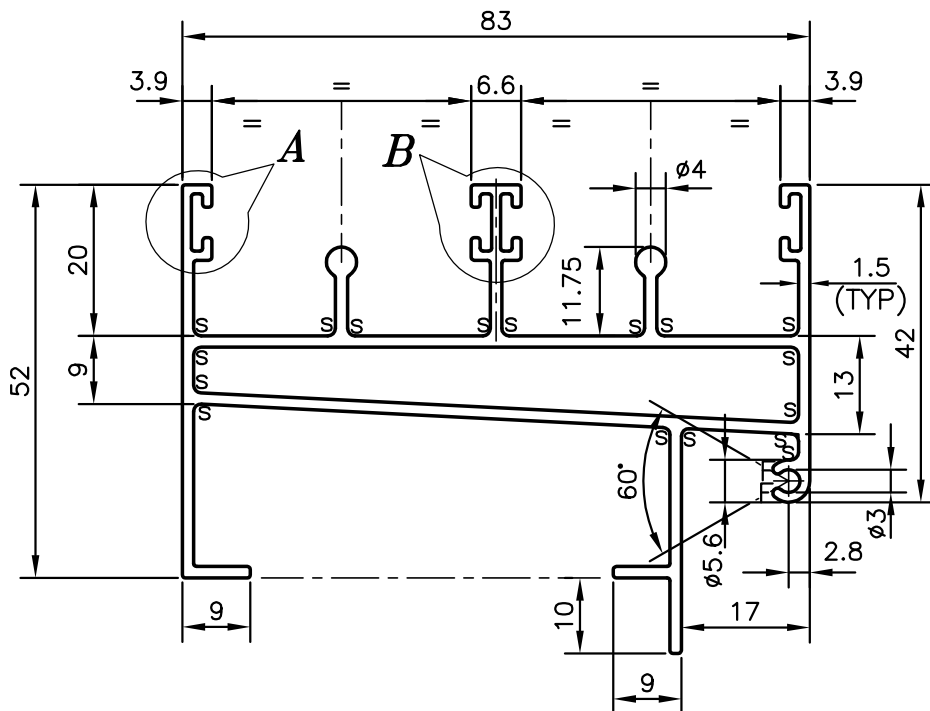

NOTE:-

1. F = FULL RADII (2 PLACES)
2. S = 1.00 mm RADII (17 PLACES)



SYMBOL OF QUALITY
AN ISO 9001 COMPANY

JINDAL ALUMINIUM LTD.
BANGALORE-560073 (INDIA)

	NAME	DATE
DRAWN	SRIVATHSA	01-01-2013
CHECKED		
APPROVED	S.S.GARG	07-01-2013
SCALE		1:1
AREA mm ²		571.48
PERIMETER mm.		577.872
WEIGHT kg/m		1.543
DRAWING No.	SECTION No.	
P-12407	-	
21407	21407	

1. ALL DIMENSIONS ARE IN mm.
2. ROUND OFF ALL SHARP CORNERS WITH 0.40 mm.
3. TOLERANCES WILL BE AS PER IS:6477-1983, UNLESS OTHERWISE SPECIFIED

PARTY'S NAME	GENERAL CATEGORY, MUMBAI MARKET
PARTY'S DRAWING No.	MODIFIED SECTION OF 21217
ALLOY & TEMPER	HE9 WP
DESCRIPTION	WINDOW SECTION-SUBFRAME 05