

P-11690
S3300
21412

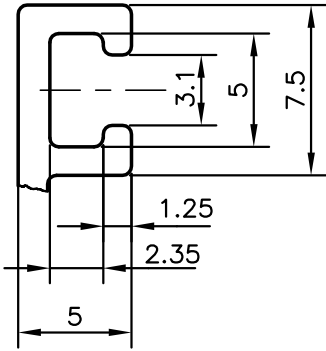

**DETAIL OF "A"**  
SCALE:- 3:1

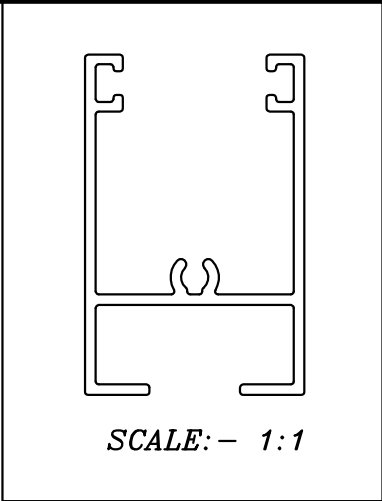

SCALE:- 1:1

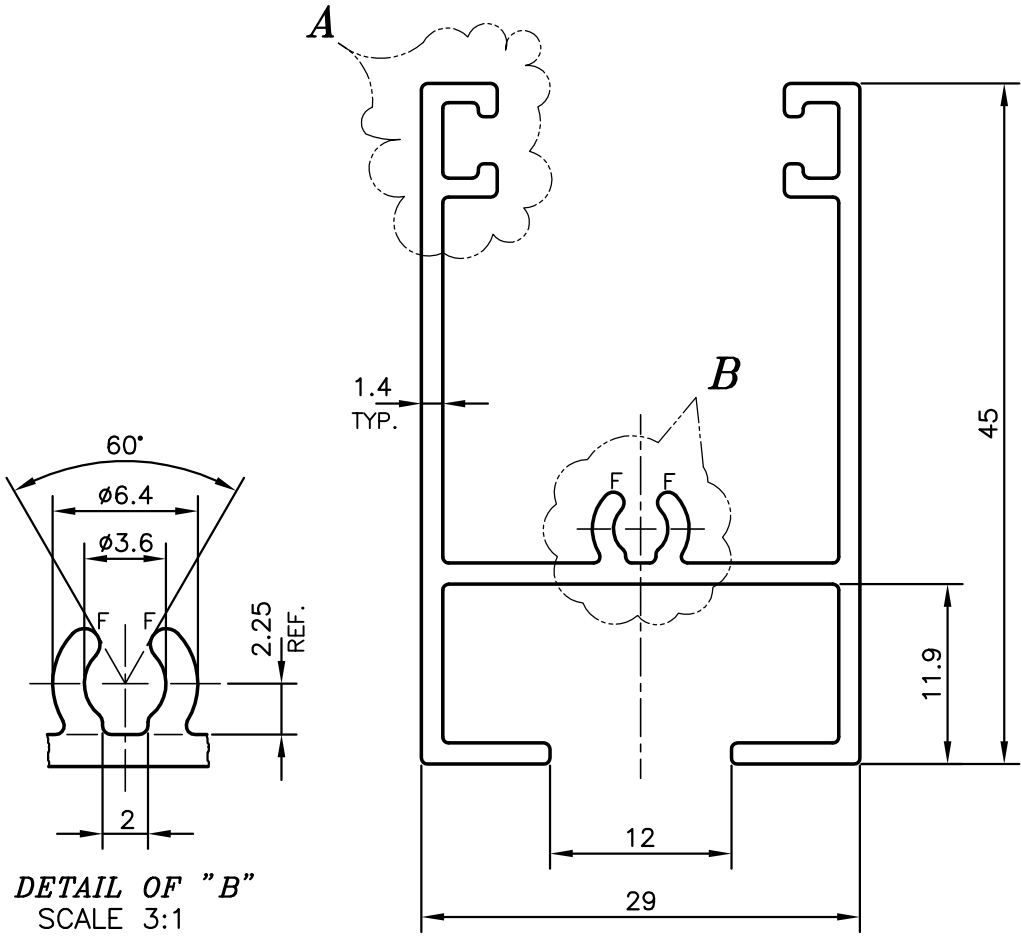

**DETAIL OF "B"**  
SCALE 3:1

Q71710

 SYMBOL OF QUALITY AN ISO 9001 COMPANY	<b>JINDAL ALUMINIUM LTD.</b> BANGALORE-560073 (INDIA)	NAME	DATE
		DRAWN	PARVESH 21-04-2012
		CHECKED	
		APPROVED	J.N.RAI 02-06-2012
		SCALE	2:1
		AREA mm <sup>2</sup>	219.302
		PERIMETER mm.	311.457
		WEIGHT kg/m	0.592
PARTY'S NAME	SAHARA PRIME CITY LTD., GURGAON	DRAWING No.	SECTION No.
PARTY'S DRAWING No.	SW6	P-11690	-
ALLOY & TEMPER	HE9 WP	S3300	S3300
		21412	21412
DESCRIPTION	WINDOW SECTION		