

P-11701

S3341

21416

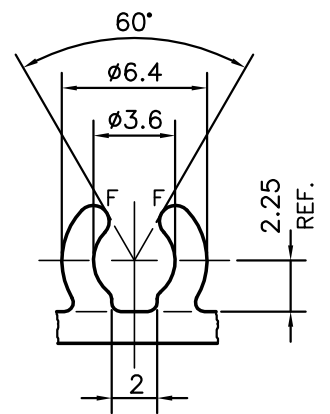
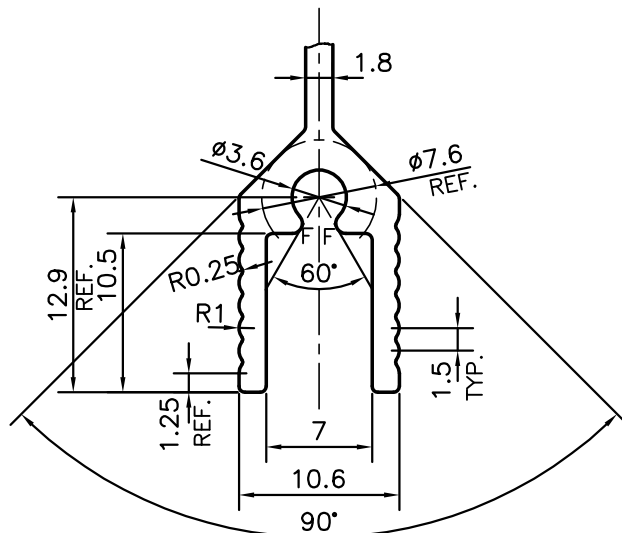
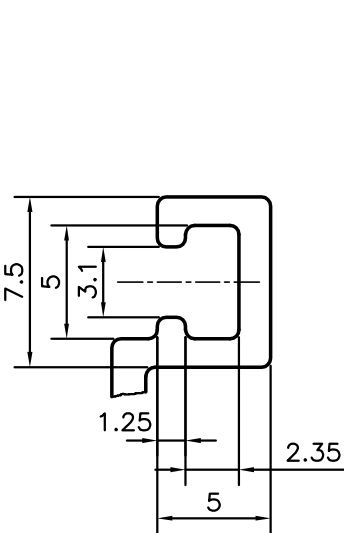
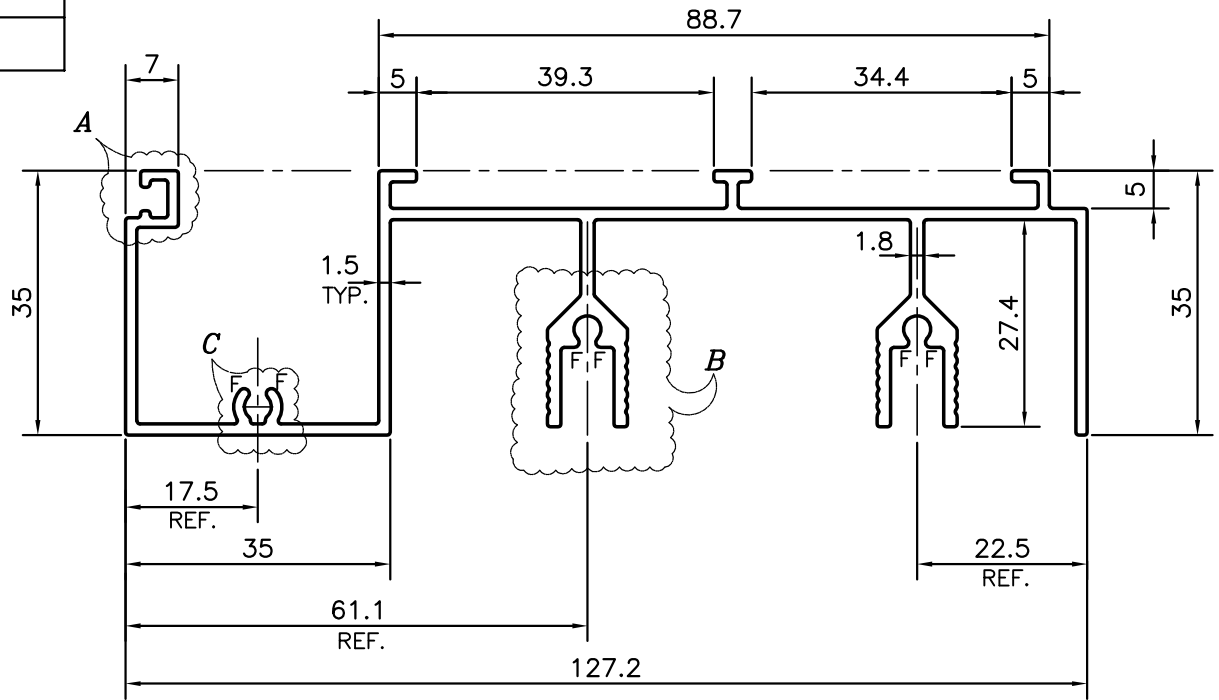

DETAIL OF "A"
SCALE 3:1

DETAIL OF "B"
SCALE 3:1

DETAIL OF "C"
SCALE 3:1

Q71724

F = FULL RADIUS (6 PLACES)



SYMBOL OF QUALITY
AN ISO 9001 COMPANY

JINDAL ALUMINIUM LTD.
BANGALORE-560073 (INDIA)

	NAME	DATE
DRAWN	PARVESH	24-04-2012
CHECKED		
APPROVED	S.S.GARG	06-06-2012
SCALE		1:1
AREA mm ²		582.553
PERIMETER mm.		714.561
WEIGHT kg/m		1.573
DRAWING No.	SECTION No.	
P-11701	-	
S3341	S3341	
21416	21416	

1. ALL DIMENSIONS ARE IN mm.
2. ROUND OFF ALL SHARP CORNERS WITH 0.40 mm.
3. TOLERANCES WILL BE AS PER IS:3965-1981 , UNLESS OTHERWISE SPECIFIED

PARTY'S NAME	SAHARA PRIME CITY LTD., GURGAON
PARTY'S DRAWING No.	SD16R
ALLOY & TEMPER	HE9 WP
DESCRIPTION	WINDOW SECTION