

P-12322

21431

DETAILS OF "B"  
SCALE 5:1

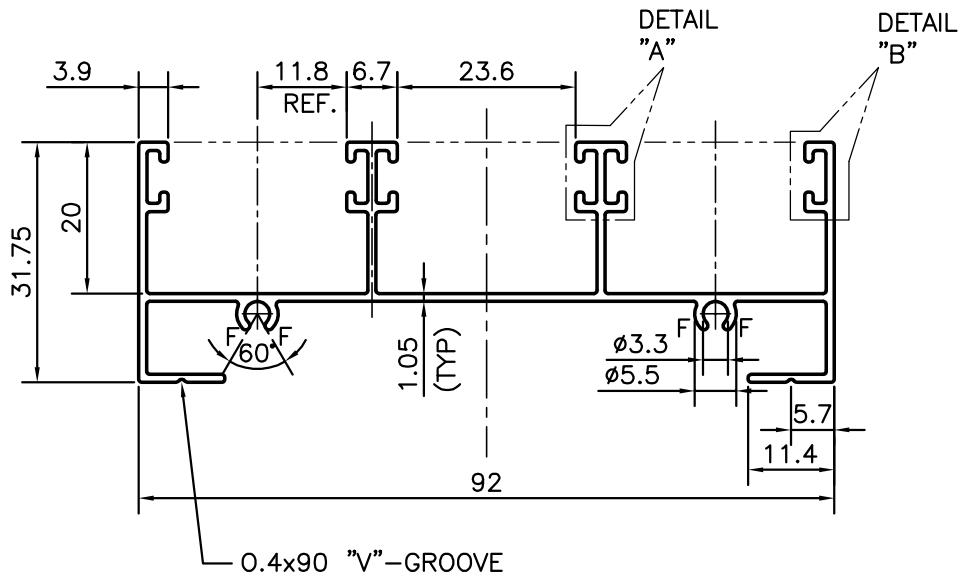
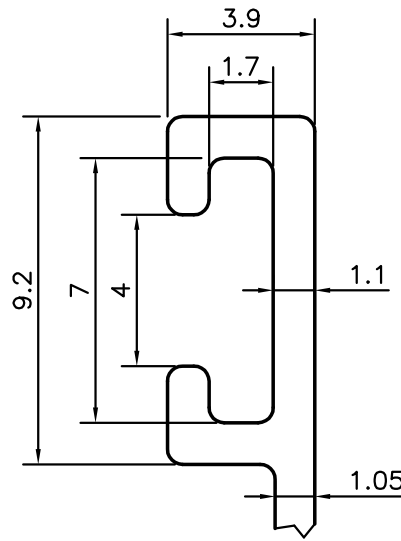
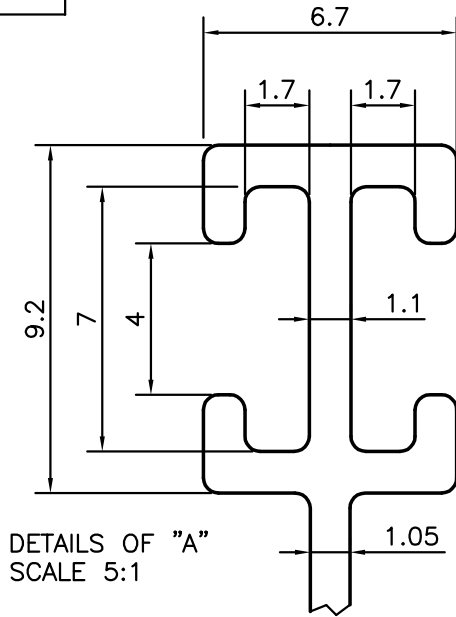

F = FULL RADIUS (4 PLACES)



SYMBOL OF QUALITY  
AN ISO 9001 COMPANY

**JINDAL ALUMINIUM LTD.**  
BANGALORE-560073 (INDIA)

	NAME	DATE
DRAWN	<b>SRIVATHSA</b>	13-12-2012
CHECKED		
APPROVED	<b>S.S.GARG</b>	03-05-2013
SCALE		1:1
AREA	mm <sup>2</sup>	301.114
PERIMETER	mm.	547.355
WEIGHT	kg/m	0.813
DRAWING No.	SECTION No.	
P-12322	-	
21431	21431	

1. ALL DIMENSIONS ARE IN mm. 2. ROUND OFF ALL SHARP CORNERS WITH 0.40 mm. 3. TOLERANCES WILL BE AS PER BS:EN-755-9, UNLESS OTHERWISE SPECIFIED	
PARTY'S NAME	PRAYOSHA ENTERPRISES LTD., UGANADA
PARTY'S DRAWING No.	MODIFIED SECTION OF 20958 (18mm SERIES)
ALLOY & TEMPER	6063 T6
DESCRIPTION	WINDOW SECTION (TOP & SIDE-3 TRACK)