

P-12332-1

21434

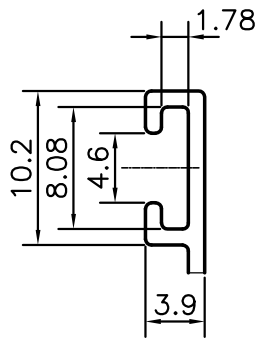

DETAIL OF "A"
SCALE:- 2:1

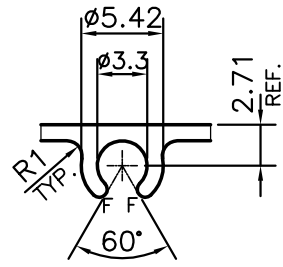

DETAIL OF "B"
SCALE:- 2:1

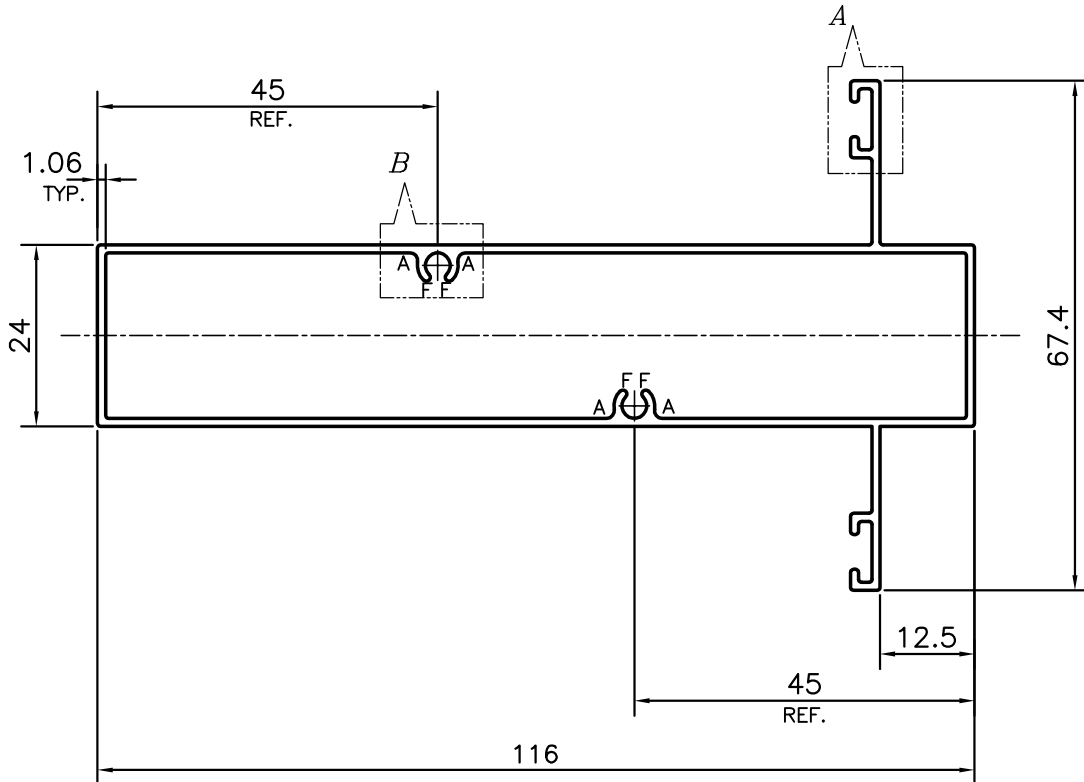

A = RADIUS 1mm. (4 PLACES)
F = FULL RADIUS (4 PLACES)



SYMBOL OF QUALITY
AN ISO 9001 COMPANY

JINDAL ALUMINIUM LTD.
BANGALORE-560073 (INDIA)

	NAME	DATE
DRAWN	PARVESH	09-01-2013
CHECKED		
APPROVED	S.S.GARG	03-05-2013
SCALE		1:1
AREA mm ²		376.733
PERIMETER mm.		398.29
WEIGHT kg/m		1.017
DRAWING No.	SECTION No.	
P-12332-1	-	
21434	21434	

1. ALL DIMENSIONS ARE IN mm.
2. ROUND OFF ALL SHARP CORNERS WITH 0.40 mm.
3. TOLERANCES WILL BE AS PER BS:EN-755-9 , UNLESS OTHERWISE SPECIFIED

PARTY'S NAME	PRAYOSHA ENTERPRISES LTD., UGANDA
PARTY'S DRAWING No.	AS PER SKETCH & REQUIREMENT
ALLOY & TEMPER	6063 T6
DESCRIPTION	WINDOW SECTION