

P-12338-1

21437

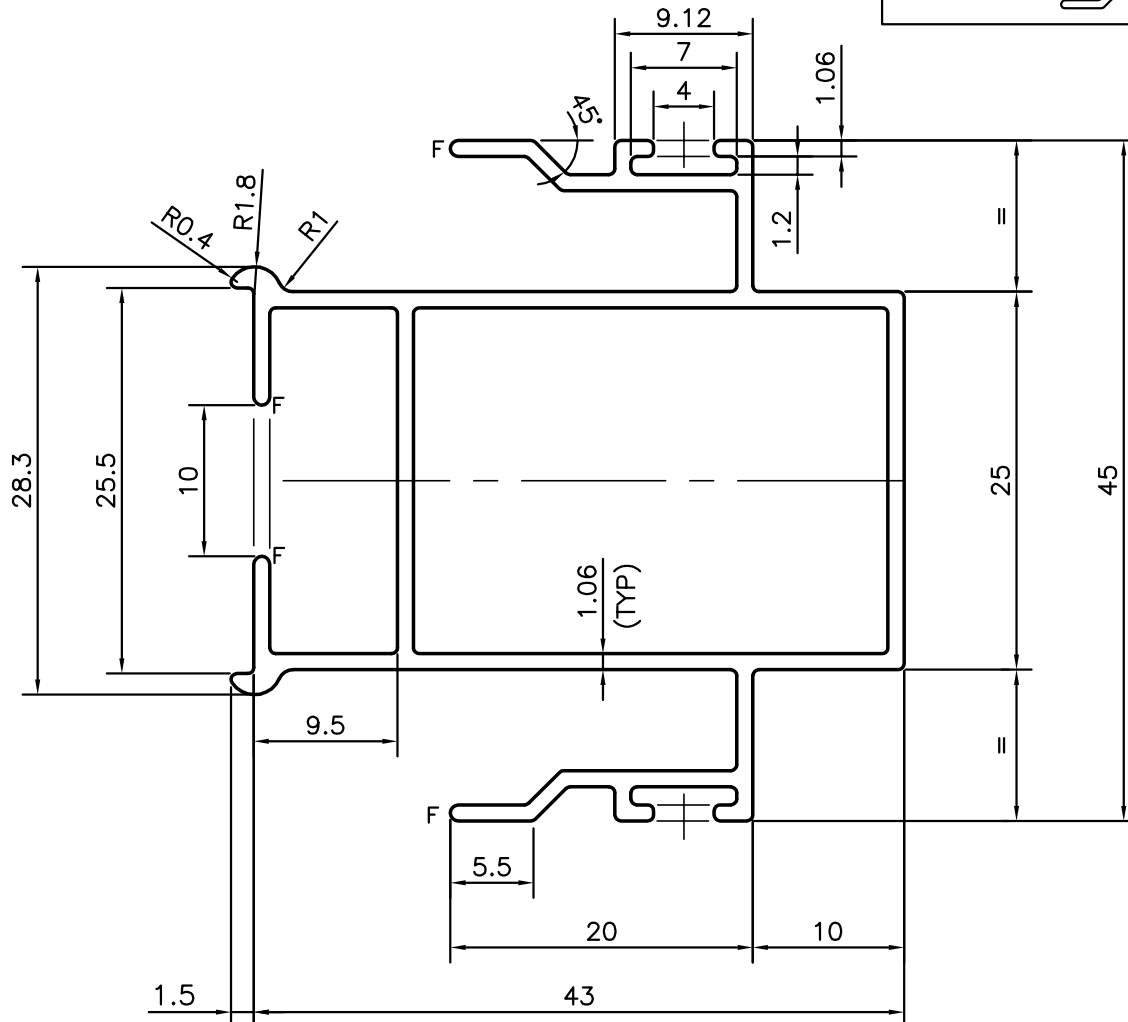

F= FULL RADIUS (4 PLACES)

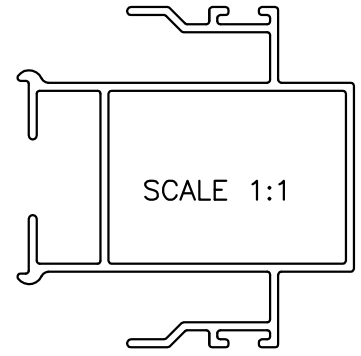

SYMBOL OF QUALITY
AN ISO 9001 COMPANY

JINDAL ALUMINIUM LTD.
BANGALORE-560073 (INDIA)

	NAME	DATE
DRAWN	SRIVATHSA	25-01-2013
CHECKED		
APPROVED	S.S.GARG	03-05-2013
SCALE		2:1
AREA mm ²		235.969
PERIMETER mm.		322.297
WEIGHT kg/m		0.637
DRAWING No.	SECTION No.	
P-12338-1	-	
21437	21437	

1. ALL DIMENSIONS ARE IN mm.
2. ROUND OFF ALL SHARP CORNERS WITH 0.40 mm.
3. TOLERANCES WILL BE AS PER BS:EN-755-9, UNLESS OTHERWISE SPECIFIED

PARTY'S NAME	PRAYOSHA ENTERPRISES LTD., UGANDA
PARTY'S DRAWING No.	AS PER SKETCH
ALLOY & TEMPER	6063 T6
DESCRIPTION	WINDOW SECTION (DOUBLE SIDE INTERLOCK)