

P-12351

21441

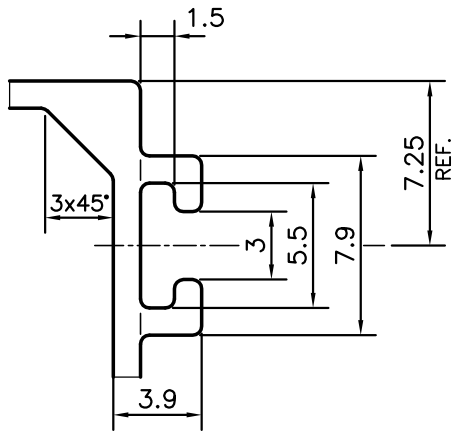

**DETAIL OF "A"**  
SCALE:- 3:1

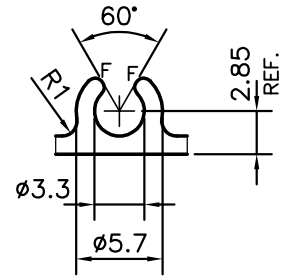

**DETAIL OF "B"**  
SCALE:- 2:1

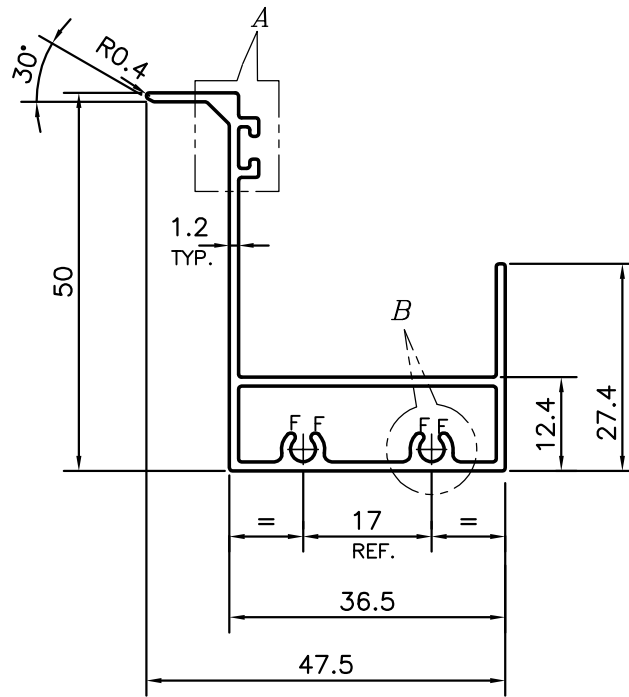

F = FULL RADIUS (4 PLACES)



SYMBOL OF QUALITY  
AN ISO 9001 COMPANY

**JINDAL ALUMINIUM LTD.**  
BANGALORE-560073 (INDIA)

	NAME	DATE
DRAWN	PARVESH	18-12-2012
CHECKED		
APPROVED	S.S.GARG	03-05-2013
SCALE		1:1
AREA mm <sup>2</sup>		223.107
PERIMETER mm.		235.11
WEIGHT kg/m		0.602
DRAWING No.	SECTION No.	
P-12351	-	
21441	21441	

1. ALL DIMENSIONS ARE IN mm.
2. ROUND OFF ALL SHARP CORNERS WITH 0.40 mm.
3. TOLERANCES WILL BE AS PER BS:EN-755-9, UNLESS OTHERWISE SPECIFIED

PARTY'S NAME	PRAYOSHA ENTERPRISES LTD., UGANDA
PARTY'S DRAWING No.	MODIFIED OF SECTION No.-21229
ALLOY & TEMPER	6063 T6
DESCRIPTION	WINDOW SECTION