

P-12733-1

S3768

21447

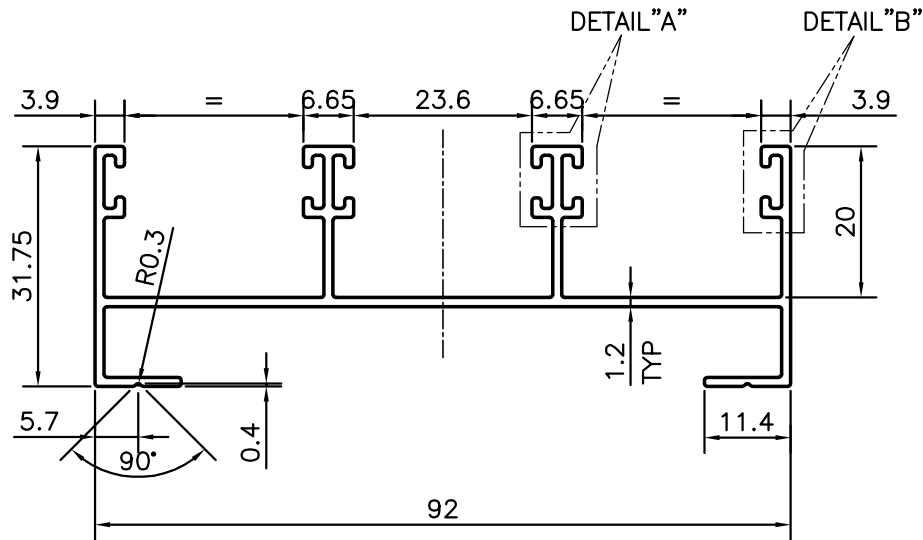
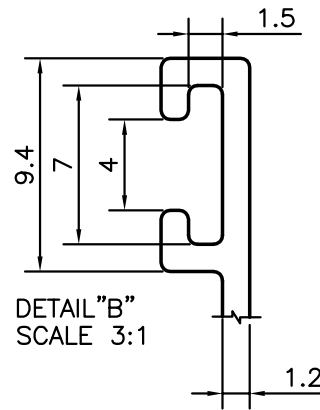
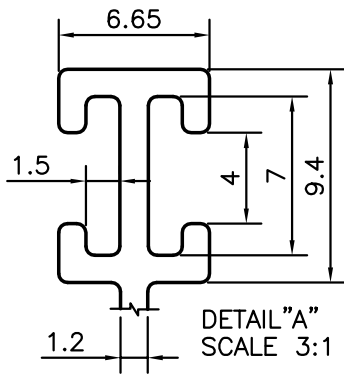

WEIGHT RANGE - ±3%
0.830kg/m TO 0.882kg/m

GENERAL WALL THICKNESS = 1.20mm

TOLERANCES ON OVERALL WIDTHS & WIDTHS ACROSS FLATS OF BARS, & REGULAR SECTIONS

UPTO 6.40mm - ±0.20	UPTO 32.0mm - ±0.38	UPTO 120.0mm - ±0.85	UPTO 320.00mm - ±1.70
UPTO 10.0mm - ±0.23	UPTO 50.0mm - ±0.46	UPTO 160.0mm - ±1.02	
UPTO 12.0mm - ±0.25	UPTO 60.0mm - ±0.53	UPTO 200.0mm - ±1.14	
UPTO 16.0mm - ±0.28	UPTO 80.0mm - ±0.69	UPTO 250.0mm - ±1.40	
UPTO 25.0mm - ±0.30	UPTO 100.0mm - ±0.75	UPTO 300.0mm - ±1.65	

 SYMBOL OF QUALITY AN ISO 9001 COMPANY	JINDAL ALUMINIUM LTD. BANGALORE-560073 (INDIA)	DRAWN	NAME	DATE
		CHECKED	RAGHAVENDRA	13-05-2013
1. ALL DIMENSIONS ARE IN mm. 2. ROUND OFF ALL SHARP CORNERS WITH 0.40 mm. 3. TOLERANCES WILL BE AS PER IS:3965-1981, UNLESS OTHERWISE SPECIFIED		APPROVED	S.S.GARG	17-05-2013
		SCALE		1:1
PARTY'S NAME GIRDHARI LAL CONSTRUCTIONS PVT. LTD., BATHINDA		AREA mm ²		316.958
		PERIMETER mm.		516.521
PARTY'S DRAWING No. LIGHTER SECTION OF 20621		WEIGHT kg/m		0.856
		DRAWING No.	SECTION No.	
ALLOY & TEMPER 6063 T6		P-12733-1		-
		S3768		S3768
DESCRIPTION WINDOW SECTION (3 TRACK SIDE & UPPER)		21447		21447