

P-12734-1

S3769

21448

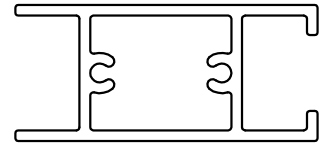

SCALE 1:1

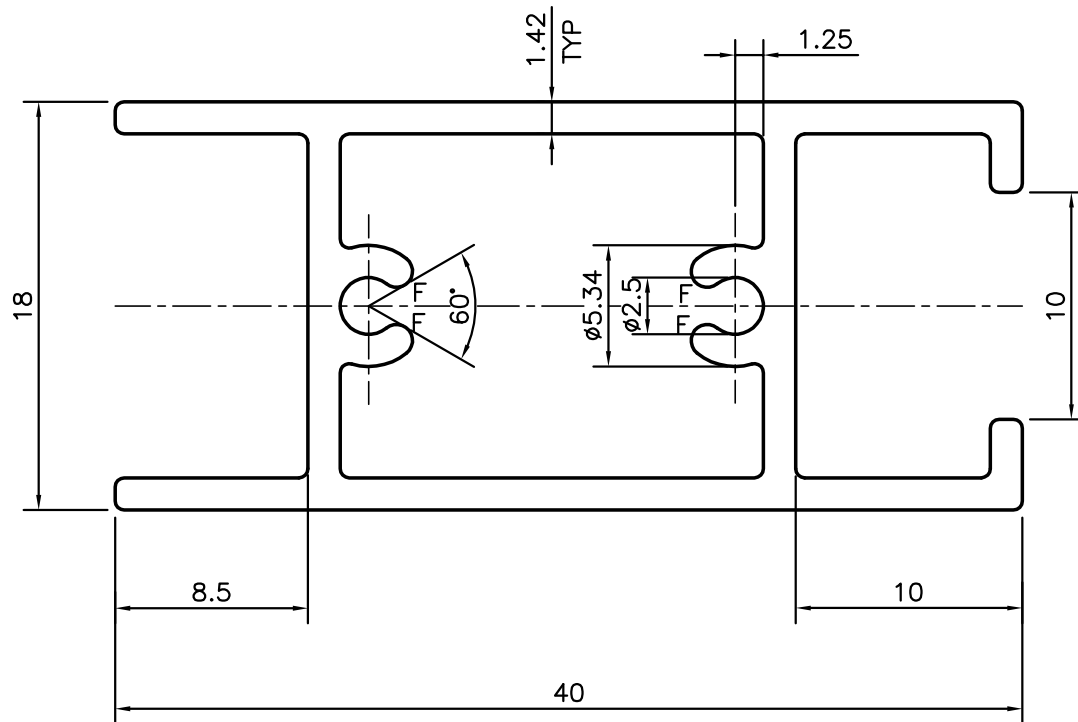

GENERAL WALL THICKNESS = 1.42mm
F = FULL RADIUS (4 PLACES)

WEIGHT RANGE - ±3%
0.479kg/m TO 0.509kg/m

TOLERANCES ON OVERALL WIDTHS & WIDTHS ACROSS FLATS OF BARS, & REGULAR SECTIONS

UPTO 6.40mm - ±0.20	UPTO 32.0mm - ±0.38	UPTO 120.0mm - ±0.85	UPTO 320.00mm - ±1.70
UPTO 10.0mm - ±0.23	UPTO 50.0mm - ±0.46	UPTO 160.0mm - ±1.02	
UPTO 12.0mm - ±0.25	UPTO 60.0mm - ±0.53	UPTO 200.0mm - ±1.14	
UPTO 16.0mm - ±0.28	UPTO 80.0mm - ±0.69	UPTO 250.0mm - ±1.40	
UPTO 25.0mm - ±0.30	UPTO 100.0mm - ±0.75	UPTO 300.0mm - ±1.65	



SYMBOL OF QUALITY
AN ISO 9001 COMPANY

JINDAL ALUMINIUM LTD.
BANGALORE-560073 (INDIA)

	NAME	DATE
DRAWN	RAGHAVENDRA	13-05-2013
CHECKED		
APPROVED	S.S.GARG	17-05-2013

- ALL DIMENSIONS ARE IN mm.
- ROUND OFF ALL SHARP CORNERS WITH 0.40 mm.
- TOLERANCES WILL BE AS PER IS:6477-1983, UNLESS OTHERWISE SPECIFIED

SCALE	3:1
AREA mm ²	182.914
PERIMETER mm.	160.573
WEIGHT kg/m	0.494

PARTY'S NAME	GIRDHARI LAL CONSTRUCTIONS PVT. LTD., BATHINDA
PARTY'S DRAWING No.	LIGHTER SECTION OF 20736
ALLOY & TEMPER	6063 T6
DESCRIPTION	WINDOW SECTION (SHUTTER)

DRAWING No.	SECTION No.
P-12734-1	-
S3769	S3769
21448	21448