

P-11024

S2976

21451

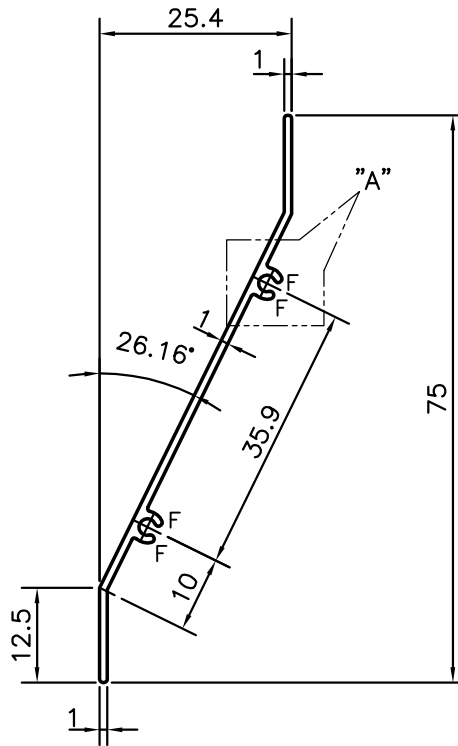
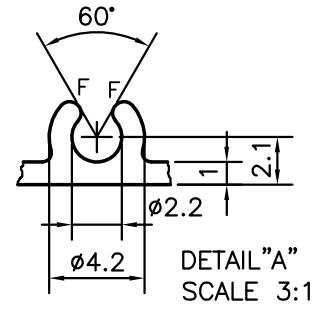

F = FULL RADIUS (4 PLACES)



SYMBOL OF QUALITY
AN ISO 9001 COMPANY

JINDAL ALUMINIUM LTD.
BANGALORE-560073 (INDIA)

	NAME	DATE
DRAWN	J.P.KAUSHIK	11-06-2011
CHECKED		
APPROVED	S.S.GARG	15-06-2011
SCALE		1:1
AREA mm ²		92.079
PERIMETER mm.		180.924
WEIGHT kg/m		0.249
DRAWING No.	SECTION No.	
P-11024	-	
S2976	S2976	
21451	21451	

1. ALL DIMENSIONS ARE IN mm.
2. ROUND OFF ALL SHARP CORNERS WITH 0.30 mm.
3. TOLERANCES WILL BE AS PER, BS:EN-755-9 UNLESS OTHERWISE SPECIFIED

PARTY'S NAME	TRIDENT ARCHITECTURAL ALUMINIUM PRODUCTS PVT. LTD., BANGALORE
PARTY'S DRAWING No.	AS PER DRAWING PROFILE-4
ALLOY & TEMPER	HE9 WP
DESCRIPTION	LOUVER SECTION