

P-12329

21458

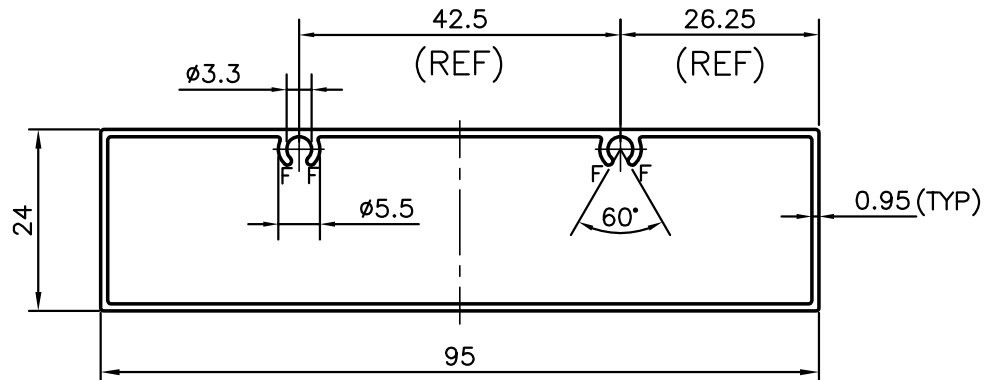

1. F= FULL RADIUS (4 PLACES)



SYMBOL OF QUALITY
AN ISO 9001 COMPANY

JINDAL ALUMINIUM LTD.
BANGALORE-560073 (INDIA)

	NAME	DATE
DRAWN	SRIVATHSA	13-12-2012
CHECKED		
APPROVED	S.S.GARG	07-09-2013
SCALE		1:1
AREA mm ²		240.922
PERIMETER mm.		237.313
WEIGHT kg/m		0.650
DRAWING No.		SECTION No.
P-12329		-
21458		21458

1. ALL DIMENSIONS ARE IN mm.
2. ROUND OFF ALL SHARP CORNERS WITH 0.40 mm.
3. TOLERANCES WILL BE AS PER BS:EN-755-9, UNLESS OTHERWISE SPECIFIED

PARTY'S NAME	PRAYOSHA ENTERPRISES LTD., UGANDA
PARTY'S DRAWING No.	AS PER SKETCH
ALLOY & TEMPER	6063 T6
DESCRIPTION	WINDOW SECTION