

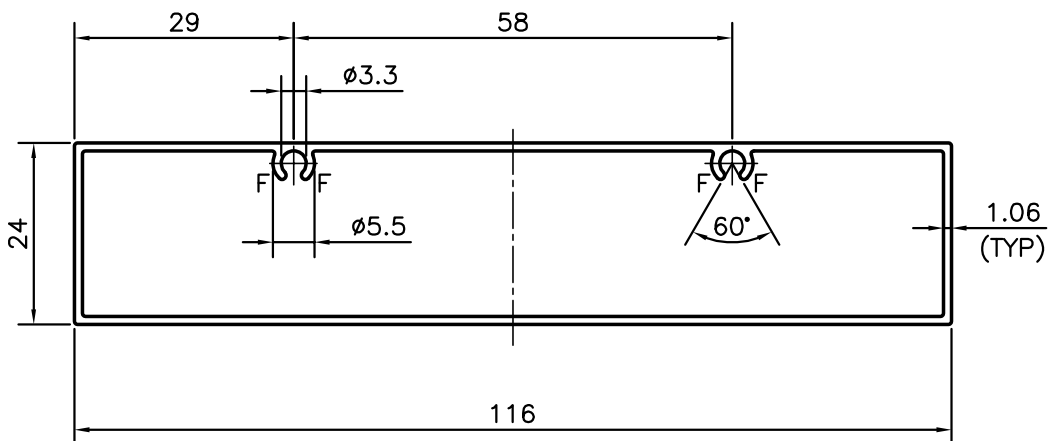

P-12331

21459



1. F= FULL RADIUS (4 PLACES)

 SYMBOL OF QUALITY AN ISO 9001 COMPANY	<b>JINDAL ALUMINIUM LTD.</b> BANGALORE-560073 (INDIA)	NAME	DATE
		DRAWN	S.RIVATHSA 13-12-2012
		CHECKED	
		APPROVED	S.S.GARG 07-09-2013
1. ALL DIMENSIONS ARE IN mm. 2. ROUND OFF ALL SHARP CORNERS WITH 0.40 mm. 3. TOLERANCES WILL BE AS PER BS:EN-755-9, UNLESS OTHERWISE SPECIFIED		SCALE	1:1
		AREA mm <sup>2</sup>	310.737
		PERIMETER mm.	279.313
PARTY'S NAME	PRAYOSHA ENTERPRISES LTD., UGANDA	WEIGHT kg/m	0.839
PARTY'S DRAWING No.	AS PER SKETCH	DRAWING No.	SECTION No.
ALLOY & TEMPER	6063 T6	P-12331	-
DESCRIPTION	WINDOW SECTION	21459	21459