

P-12335-1

21460

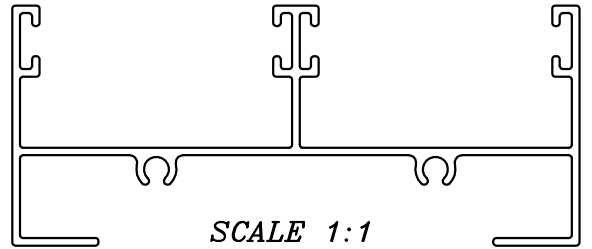

SCALE 1:1

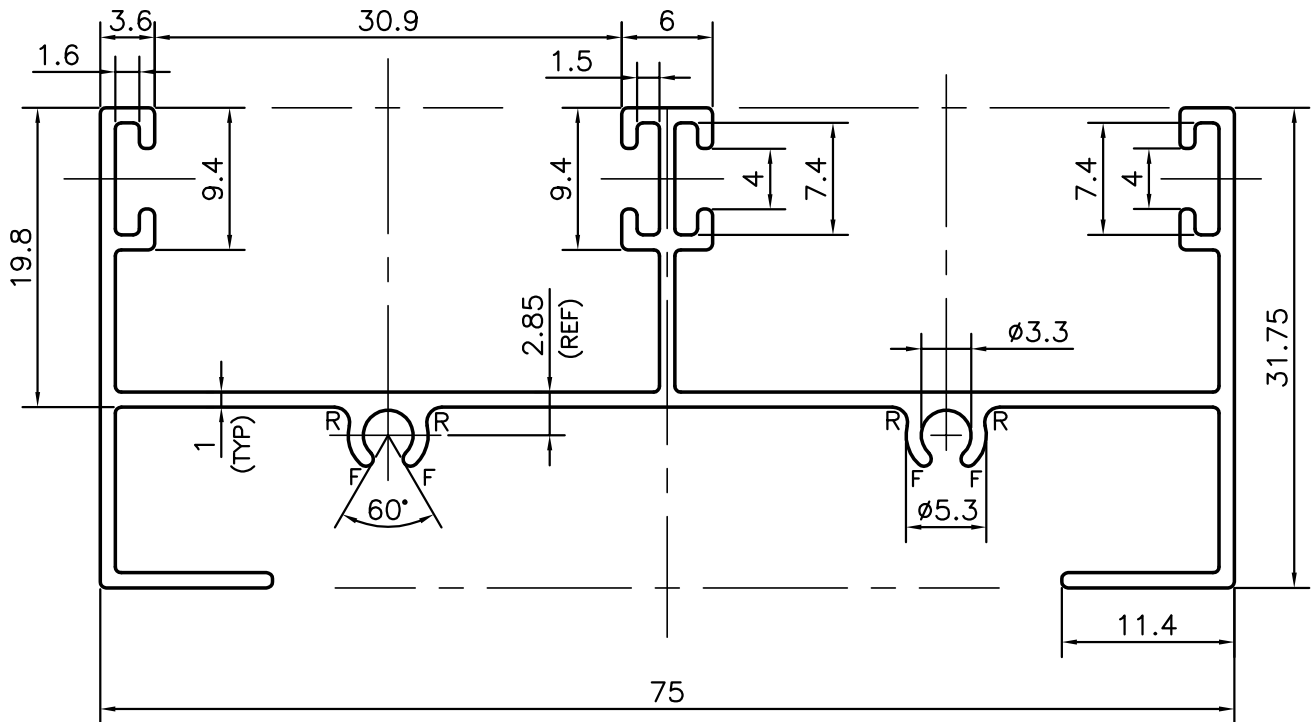

F = FULL RADIUS (4 PLACES)  
R = 1 mm RADIUS (4 PLACES)



SYMBOL OF QUALITY  
AN ISO 9001 COMPANY

**JINDAL ALUMINIUM LTD.**  
BANGALORE-560073 (INDIA)

|                      | NAME        | DATE       |
|----------------------|-------------|------------|
| DRAWN                | SRIVATHSA   | 07-01-2013 |
| CHECKED              |             |            |
| APPROVED             | S.S.GARG    | 07-09-2013 |
| SCALE                | 2:1         |            |
| AREA mm <sup>2</sup> | 229.89      |            |
| PERIMETER mm.        | 438.04      |            |
| WEIGHT kg/m          | 0.621       |            |
| DRAWING No.          | SECTION No. |            |
| P-12335-1            | -           |            |
| 21460                | 21460       |            |
|                      |             |            |
|                      |             |            |

1. ALL DIMENSIONS ARE IN mm.
2. ROUND OFF ALL SHARP CORNERS WITH 0.40 mm.
3. TOLERANCES WILL BE AS PER BS:EN-755-9, UNLESS OTHERWISE SPECIFIED

|                     |                                       |
|---------------------|---------------------------------------|
| PARTY'S NAME        | PRAYOSHA ENTERPRISES LTD., UGANDA     |
| PARTY'S DRAWING No. | AS PER SKETCH (25 mm. SERIES)         |
| ALLOY & TEMPER      | 6063 T6                               |
| DESCRIPTION         | WINDOW SECTION (TOP & SIDE 2 - TRACK) |