

P-12337-1

21461

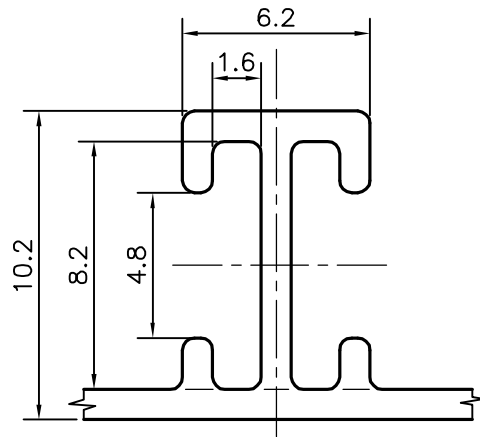

DETAILS OF "A"  
SCALE 4:1

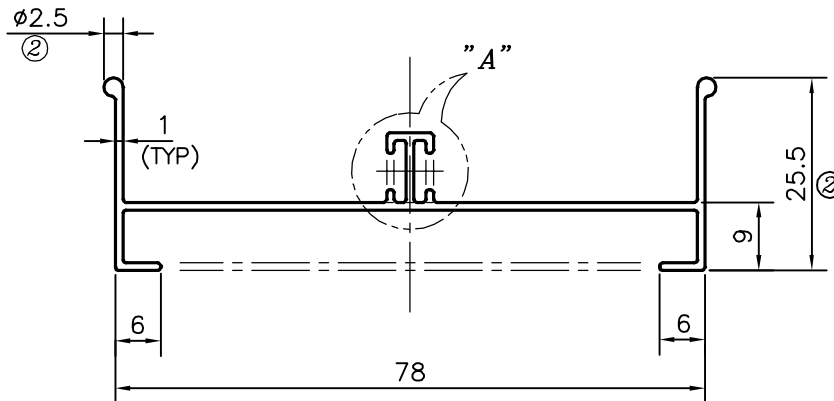

**ISSUE (2) :-**

- ☞  $\phi 2.5$ - 2 BULB ADDED ACCORDINGLY DIMENSION ALSO CHANGED FROM 24 TO 25.5 mm AT BOTH ENDS.
- ☞ WEIGHT ALSO CHANGED FROM 0.419 kg/m. TO 0.442 kg/m.



SYMBOL OF QUALITY  
AN ISO 9001 COMPANY

**JINDAL ALUMINIUM LTD.**  
BANGALORE-560073 (INDIA)

	NAME	DATE
DRAWN	PARVESH	11-06-2015
CHECKED		
APPROVED	S.S.GARG	17-06-2015
SCALE		1:1
AREA	mm <sup>2</sup>	163.752
PERIMETER	mm.	315.357
WEIGHT	kg/m	0.442
DRAWING No.	SECTION No.	
P-12337-1	-	
21461	21461 (ISSUE-2)	

1. ALL DIMENSIONS ARE IN mm.
2. ROUND OFF ALL SHARP CORNERS WITH 0.40 mm.
3. TOLERANCES WILL BE AS PER BS:EN-755-9, UNLESS OTHERWISE SPECIFIED

PARTY'S NAME	PRAYOSHA ENTERPRISES LTD., UGANDA
PARTY'S DRAWING No.	AS PER SKETCH (25mm SERIES)
ALLOY & TEMPER	6063 T6
DESCRIPTION	WINDOW SECTION (2-TRACK VERTICAL)