

P-12367-1

21467

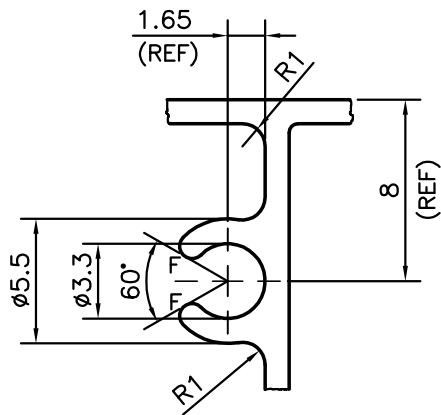

DETAILS OF "A"
SCALE 3:1

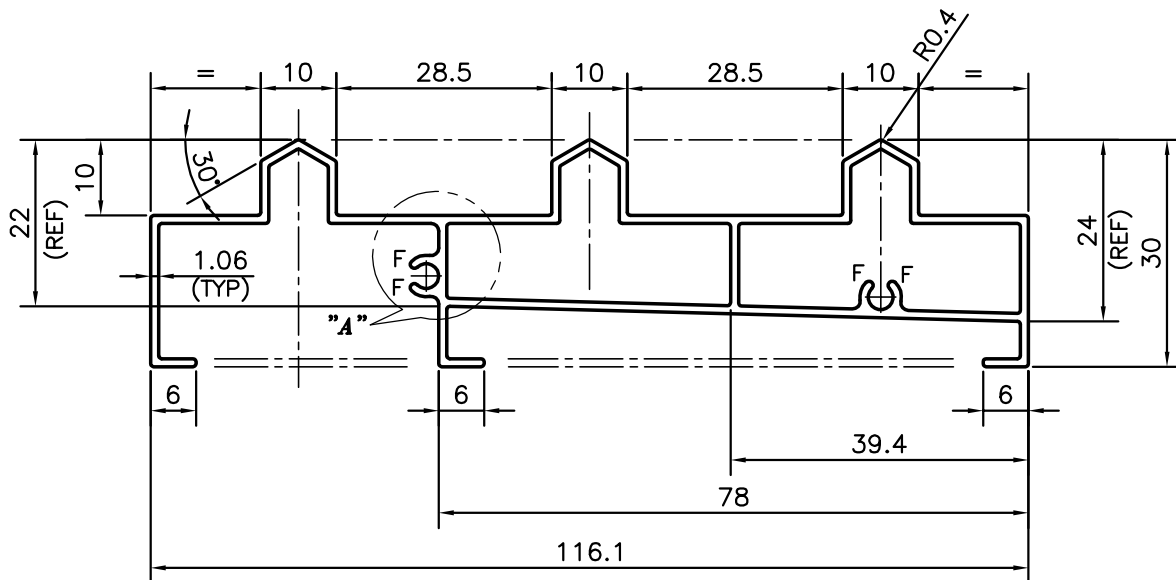

F = FULL RADIUS (4 PLACES)



SYMBOL OF QUALITY
AN ISO 9001 COMPANY

JINDAL ALUMINIUM LTD.
BANGALORE-560073 (INDIA)

	NAME	DATE
DRAWN	SRIVATHSA	28-01-2013
CHECKED		
APPROVED	S.S.GARG	07-09-2013

1. ALL DIMENSIONS ARE IN mm.
2. ROUND OFF ALL SHARP CORNERS WITH 0.40 mm.
3. TOLERANCES WILL BE AS PER BS:EN-755-9, UNLESS OTHERWISE SPECIFIED

SCALE	1:1
AREA mm ²	362.525
PERIMETER mm.	425.358
WEIGHT kg/m	0.979

PARTY'S NAME PRAYOSHA ENTERPRISES LTD., UGANDA

DRAWING No.	SECTION No.
P-12367-1	-
21467	21467

PARTY'S DRAWING No. AS PER SKETCH (25mm SERIES)

ALLOY & TEMPER 6063 T6

DESCRIPTION WINDOW SECTION (3 TRACK BOTTOM)