

P-12987

21468

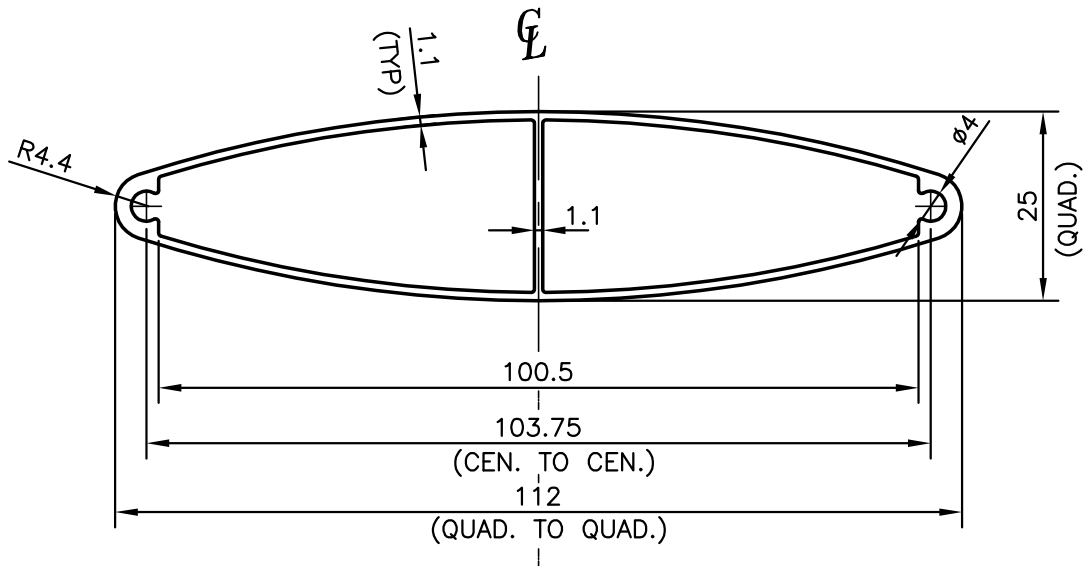

TOLERANCE CHART CD = CIRCUMSCRIBING CIRCLE

DIMENSION	CD<100	100<CD<200	200<CD<300	300<CD<500
UPTO 10mm	±0.25	±0.30	±0.35	±0.40
10.0 -25.0	±0.30	±0.40	±0.50	±0.60
25.0 -50.0	±0.50	±0.60	±0.80	±0.90
50.0 -100	±0.70	±0.90	±1.10	±1.30
100 - 150	-	±1.10	±1.30	±1.50
150 - 200	-	±1.3	±1.50	±1.80
200 - 300	-	-	±1.70	±2.10
300 - 450	-	-	-	±2.80



SYMBOL OF QUALITY
AN ISO 9001 COMPANY

JINDAL ALUMINIUM LTD.
BANGALORE-560073 (INDIA)

	NAME	DATE
DRAWN	SRIVATHSA	29-08-2013
CHECKED		
APPROVED	S.S.GARG	07-09-2013

- ALL DIMENSIONS ARE IN mm.
- ROUND OFF ALL SHARP CORNERS WITH 0.40 mm.
- TOLERANCES WILL BE AS PER BS:EN-755-9 , UNLESS OTHERWISE SPECIFIED

SCALE	1:1
AREA mm ²	312.39
PERIMETER mm.	237.421
WEIGHT kg/m	0.843
DRAWING No.	SECTION No.
P-12987	-
21468	21468

PARTY'S NAME	PRAYOSHA ENTERPRISES LTD., UGANDA
PARTY'S DRAWING No.	AS PER DRAWING
ALLOY & TEMPER	6063 T6
DESCRIPTION	LOUVER SECTION