

P-13063

21471

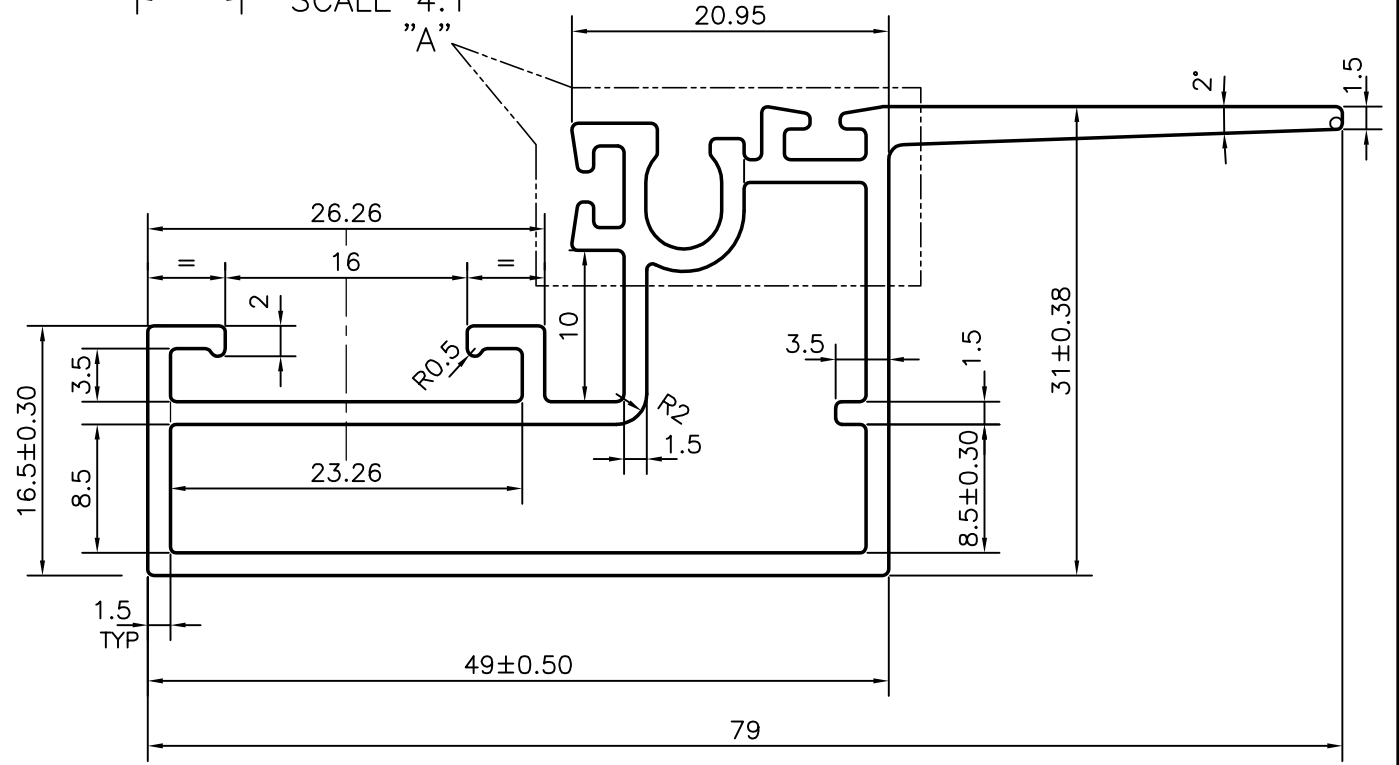
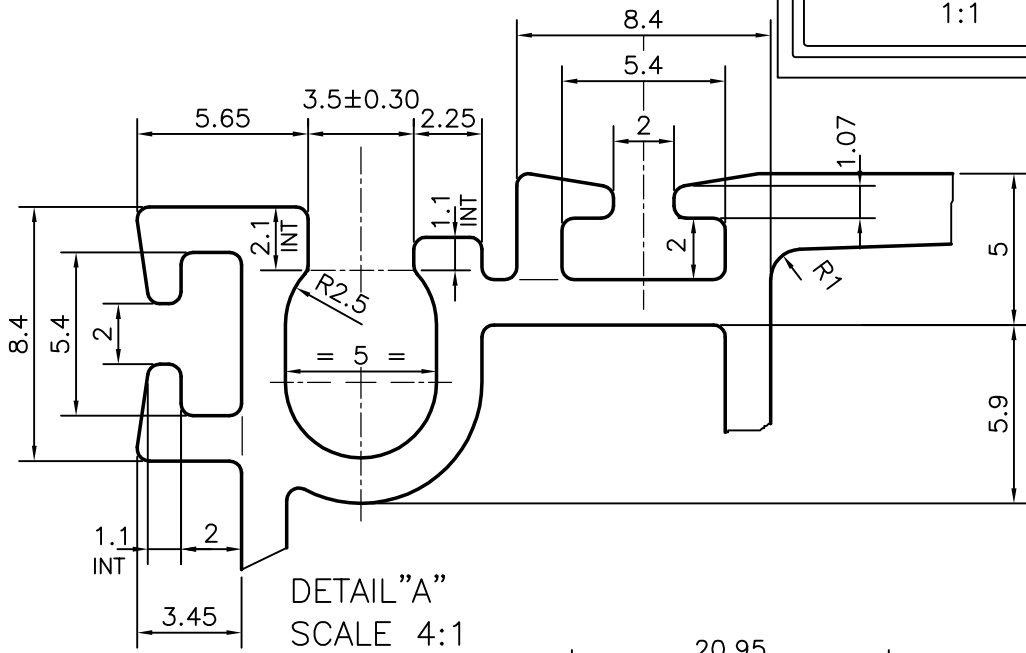
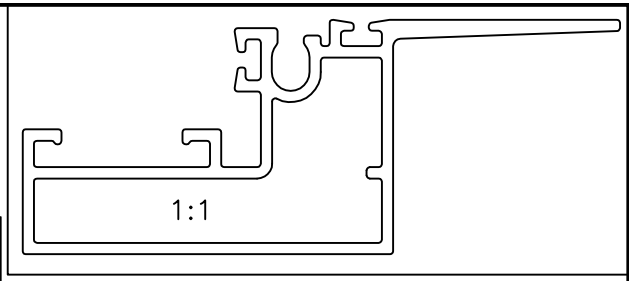

SYMBOL OF QUALITY
AN ISO 9001 COMPANY

JINDAL ALUMINIUM LTD.
BANGALORE-560073 (INDIA)

		NAME	DATE
DRAWN		SRIVATHSA	04-10-2013
CHECKED			
APPROVED		S.S.GARG	28-10-2013
SCALE		2:1	
AREA mm ²		354.363	
PERIMETER mm.		299.472	
WEIGHT kg/m		0.957	
DRAWING No.		SECTION No.	
P-13063		-	
21471		21471	

1. ALL DIMENSIONS ARE IN mm.
2. ROUND OFF ALL SHARP CORNERS WITH 0.40 mm.
3. TOLERANCES WILL BE AS PER,IS:6477-1983 UNLESS OTHERWISE SPECIFIED

PARTY'S NAME	GENERAL CATEGORY , BANGALORE MARKET
PARTY'S DRAWING No.	AS PER DRAWING
ALLOY & TEMPER	HE9 WP
DESCRIPTION	MISC. SECTION