

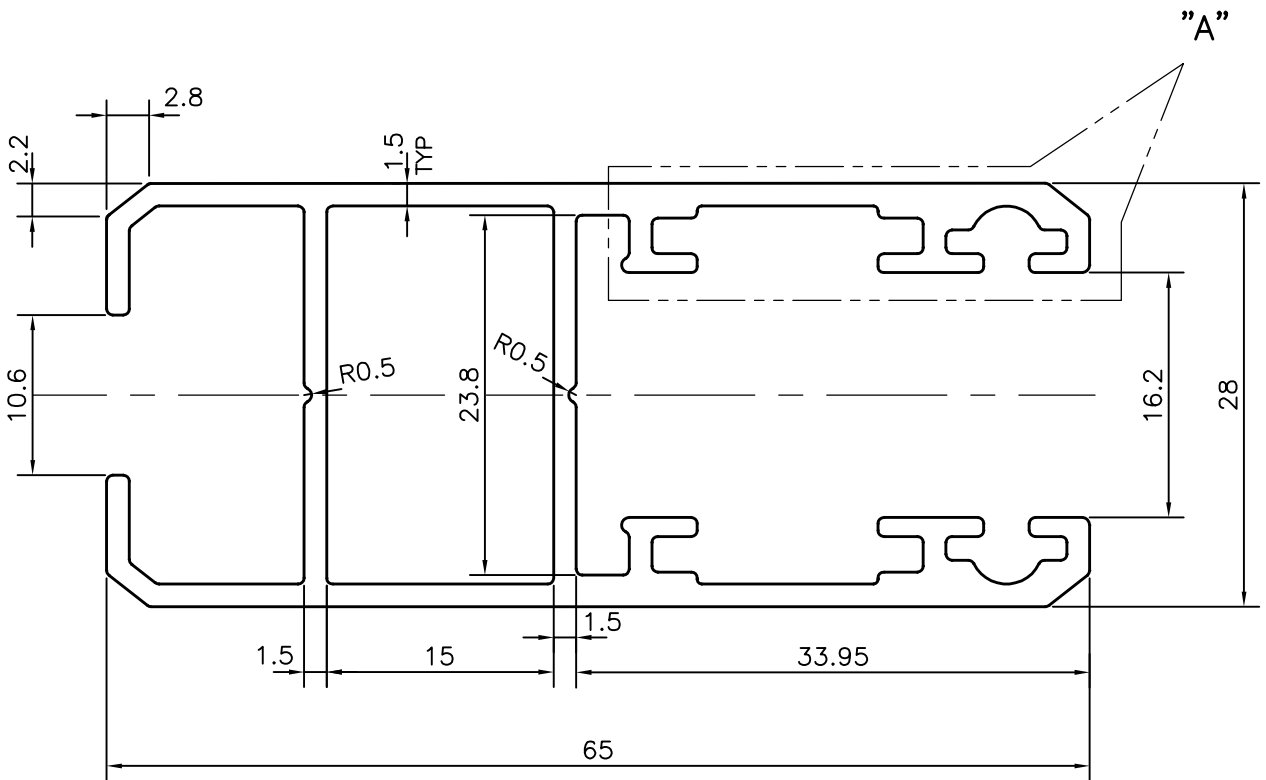

P-11974
X1611
21481

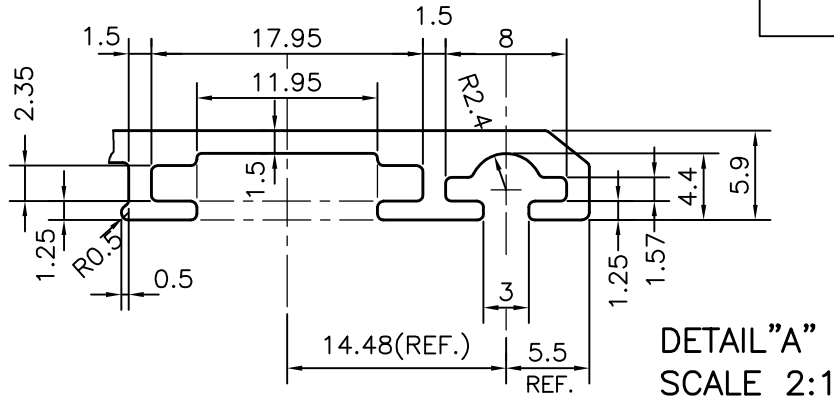
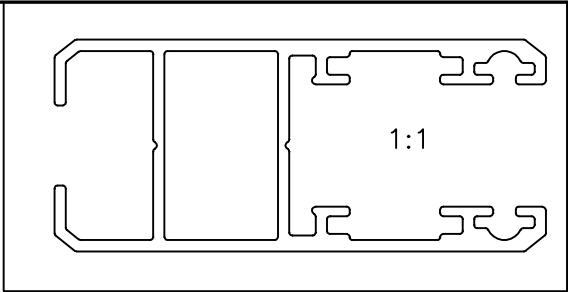

 SYMBOL OF QUALITY AN ISO 9001 COMPANY	JINDAL ALUMINIUM LTD. BANGALORE-560073 (INDIA)	DRAWN	NAME	DATE
		CHECKED	J.P.KAUSHIK	16-08-2012
1. ALL DIMENSIONS ARE IN mm. 2. ROUND OFF ALL SHARP CORNERS WITH 0.40 mm. 3. TOLERANCES WILL BE AS PER,BS:EN-755-9 UNLESS OTHERWISE SPECIFIED		APPROVED	S.S.CARG	01-09-2012
		SCALE		2:1
PARTY'S NAME AMBICA ALUMINIUM COMPANY, BANGALORE		AREA mm ²		377.697
		PERIMETER mm.		384.393
PARTY'S DRAWING No. 6202 65x28		WEIGHT kg/m		1.020
		DRAWING No.	SECTION No.	
ALLOY & TEMPER 63400 WP		P-11974	-	
		X1611	X1611	
DESCRIPTION SHUTTER SECTION		21481	21481	