

P-11975
X1612
21482

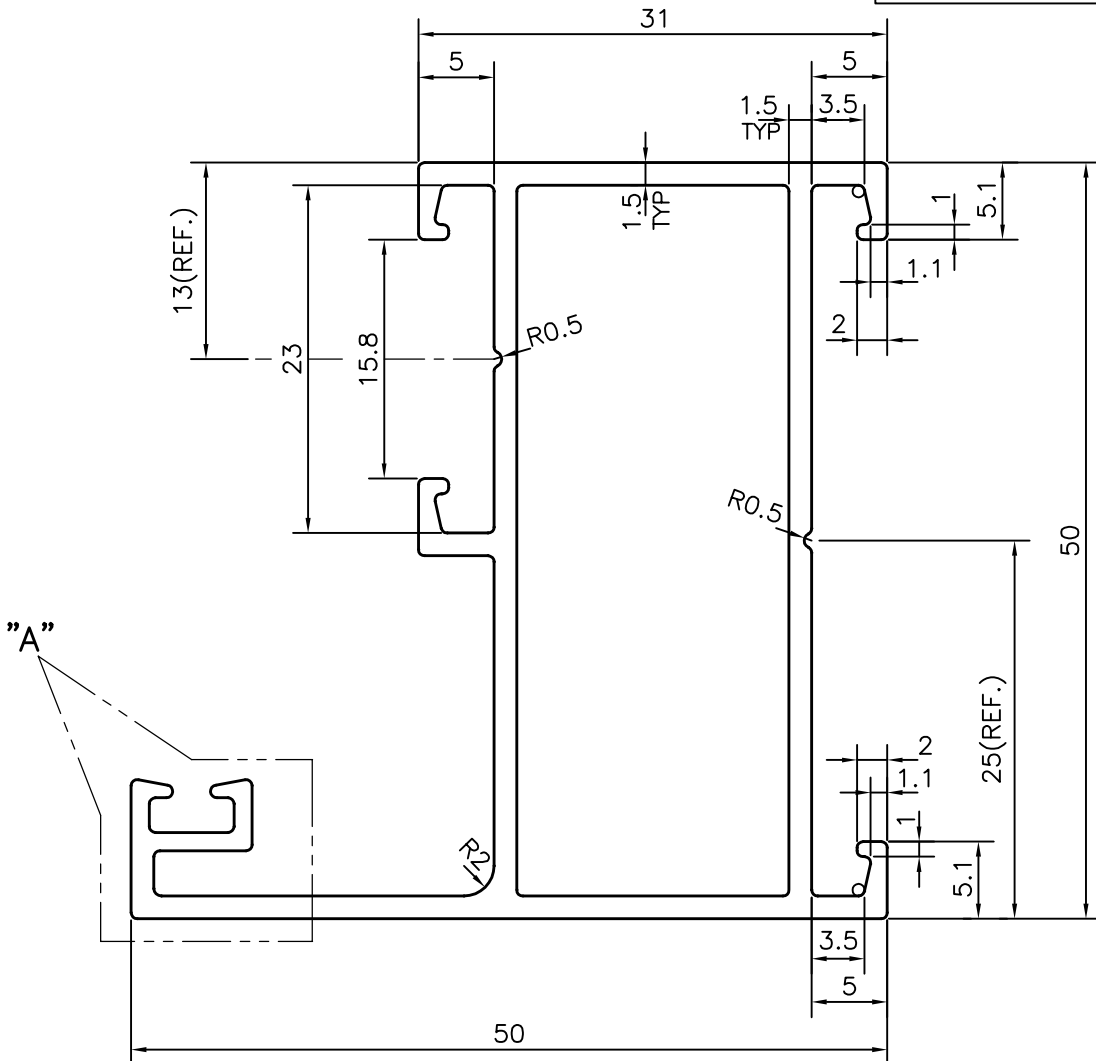

ISSUE:-2

RADIUS CHANGED FROM RADIUS 2 TO 0.4 RADIUS
WEIGHT ALSO CHANGED FROM 0.853 kg/M TO 0.855 kg/M

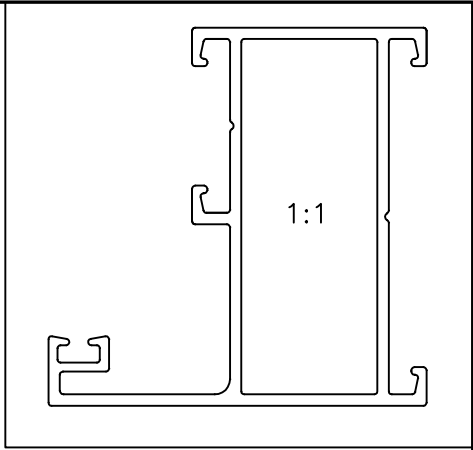
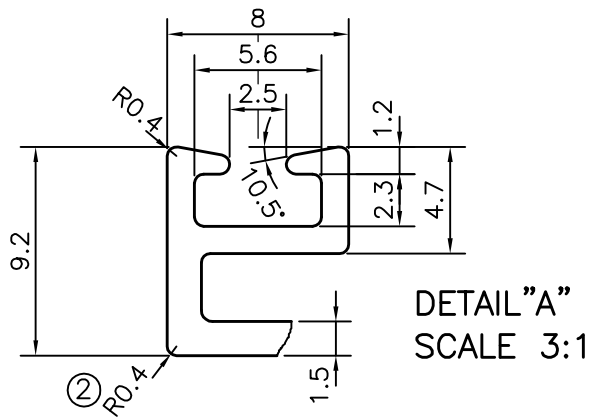

SYMBOL OF QUALITY
AN ISO 9001 COMPANY

JINDAL ALUMINIUM LTD.
BANGALORE-560073 (INDIA)

	NAME	DATE
DRAWN	J.P.KAUSHIK	14-11-2012
CHECKED		
APPROVED	S.S.CARG	20-11-2012
SCALE		2:1
AREA mm ²		316.689
PERIMETER mm.		297.978
WEIGHT kg/m		0.855
DRAWING No.	SECTION No.	
P-11975	-	
X1612	X1612(ISSUE-2)	
21482	21482	

1. ALL DIMENSIONS ARE IN mm.
2. ROUND OFF ALL SHARP CORNERS WITH 0.40 mm.
3. TOLERANCES WILL BE AS PER,BS:EN-755-9 UNLESS OTHERWISE SPECIFIED

PARTY'S NAME	AMBICA ALUMINIUM COMPANY, BANGALORE
PARTY'S DRAWING No.	6202 50x50
ALLOY & TEMPER	63400 WP
DESCRIPTION	WINDOW SECTION