

P-13337

21490

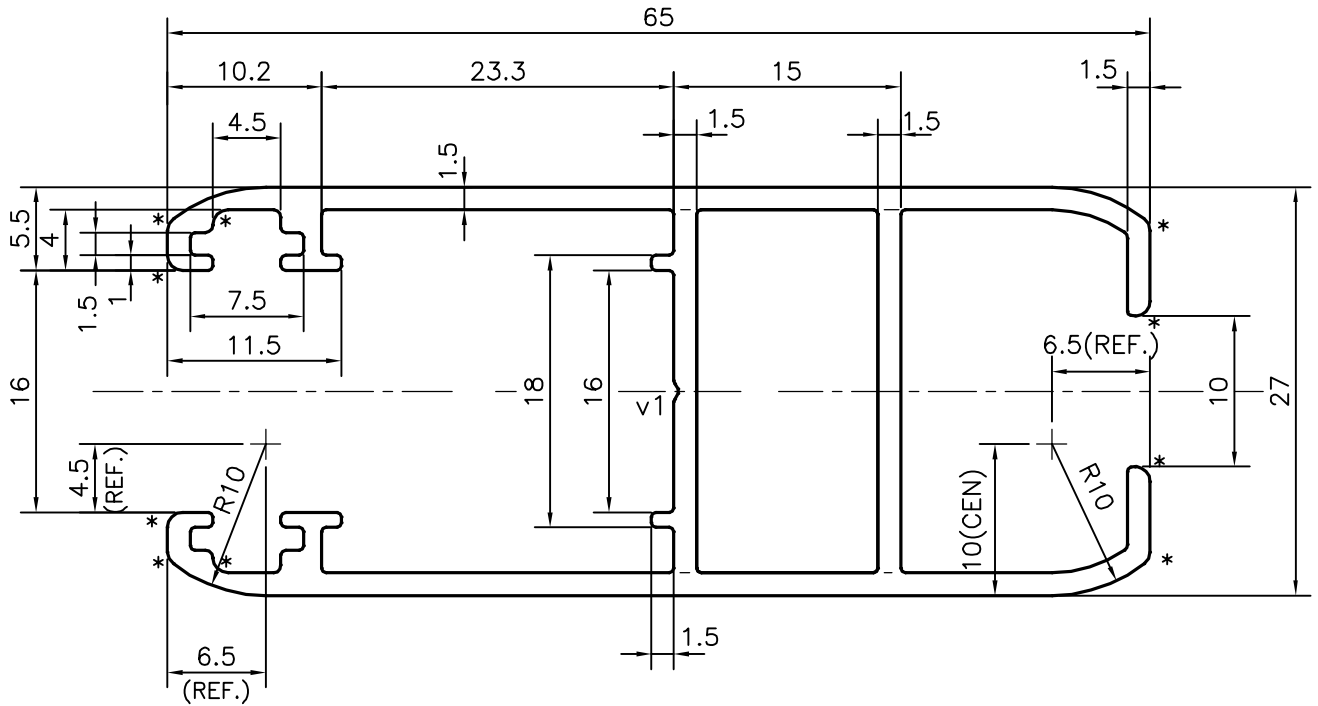
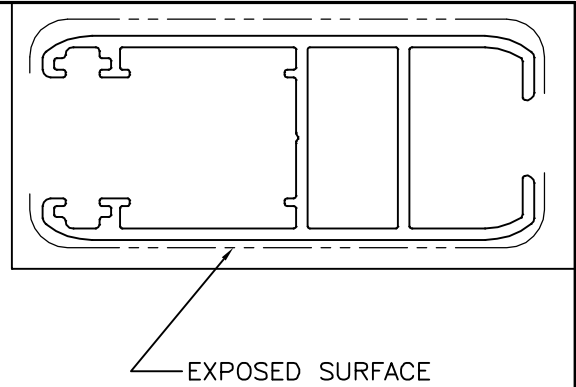
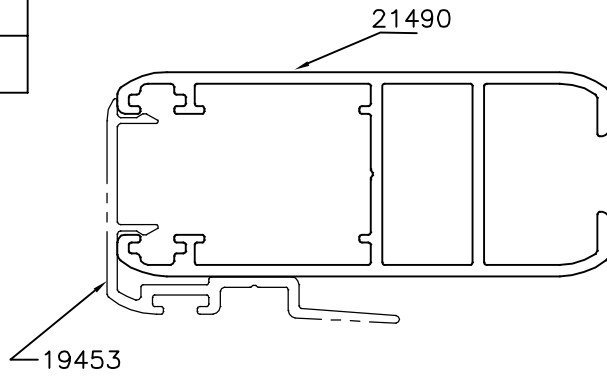

METHOD OF BUNDLING (PACKING)

SCALE  
N.T.S.

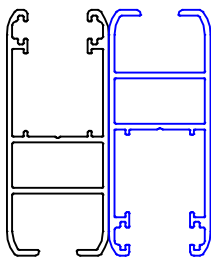

v1 = V GROOVE 0.3x120°  
\* = 1.0 RADIUS (10 PLACES )



SYMBOL OF QUALITY  
AN ISO 9001 COMPANY

**JINDAL ALUMINIUM LTD.**  
BANGALORE-560073 (INDIA)

		NAME	DATE
DRAWN		SRIVATHSA	13-01-2014
CHECKED			
APPROVED		S.S.GARG	30-01-2014
SCALE			2:1
AREA mm <sup>2</sup>			315.104
PERIMETER mm.			348.629
WEIGHT kg/m			0.851
DRAWING No.		SECTION No.	
P-13337		-	
21490		21490	

1. ALL DIMENSIONS ARE IN mm.
2. ROUND OFF ALL SHARP CORNERS WITH 0.40 mm.
3. TOLERANCES WILL BE AS PER,IS:6477-1983 UNLESS OTHERWISE SPECIFIED

PARTY'S NAME	GENERAL CATEGORY, MUMBAI MARKET
PARTY'S DRAWING No.	AS PER DRAWING
ALLOY & TEMPER	6063 T6
DESCRIPTION	WINDOW SECTION