

P-11670

S3276

21502

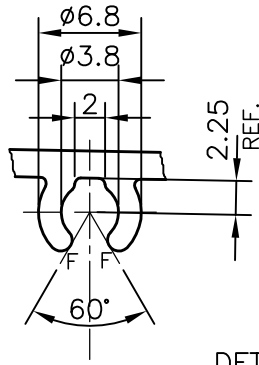

DETAIL OF "C"
SCALE 2:1

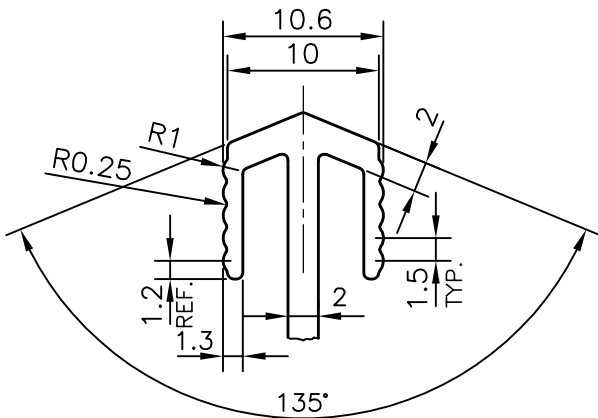
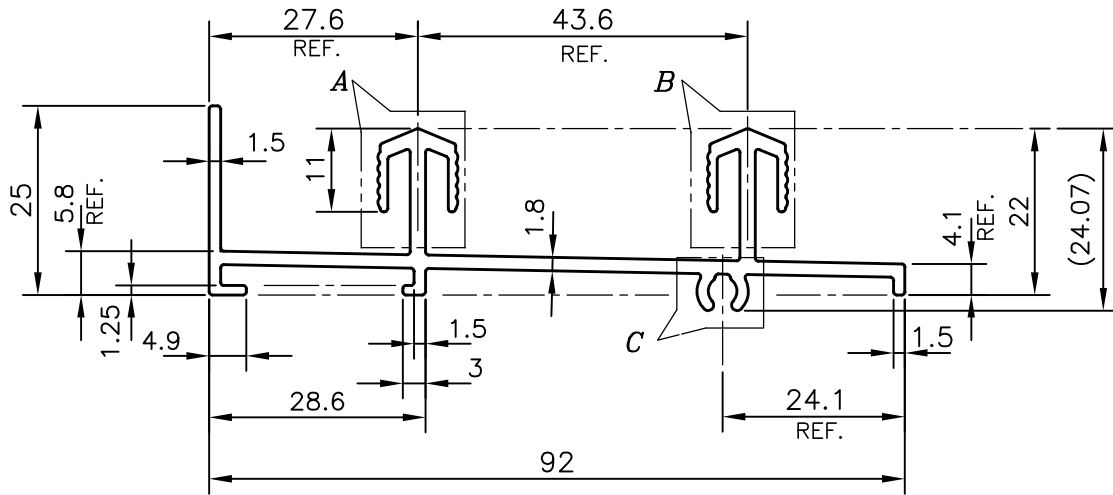

DETAIL OF "A" "B"
SCALE 2:1

F = FULL RADIUS (2 PLACES)

Q71725



SYMBOL OF QUALITY
AN ISO 9001 COMPANY

JINDAL ALUMINIUM LTD.
BANGALORE-560073 (INDIA)

	NAME	DATE
DRAWN	PARVESH	21-04-2012
CHECKED		
APPROVED	R.G.PAREKH	17-05-2012
SCALE		1:1
AREA	mm ²	367.378
PERIMETER	mm.	426.017
WEIGHT	kg/m	0.992
DRAWING No.	SECTION No.	
P-11670	-	
S3276	S3276	
21502	21502	

1. ALL DIMENSIONS ARE IN mm.
2. ROUND OFF ALL SHARP CORNERS WITH 0.40 mm.
3. TOLERANCES WILL BE AS PER IS:3965-1981, UNLESS OTHERWISE SPECIFIED

PARTY'S NAME	SAHARA PRIME CITY LTD., LUCKNOW
PARTY'S DRAWING No.	SD17R
ALLOY & TEMPER	HE9 WP
DESCRIPTION	WINDOW SECTION