

P-13839-1

21510

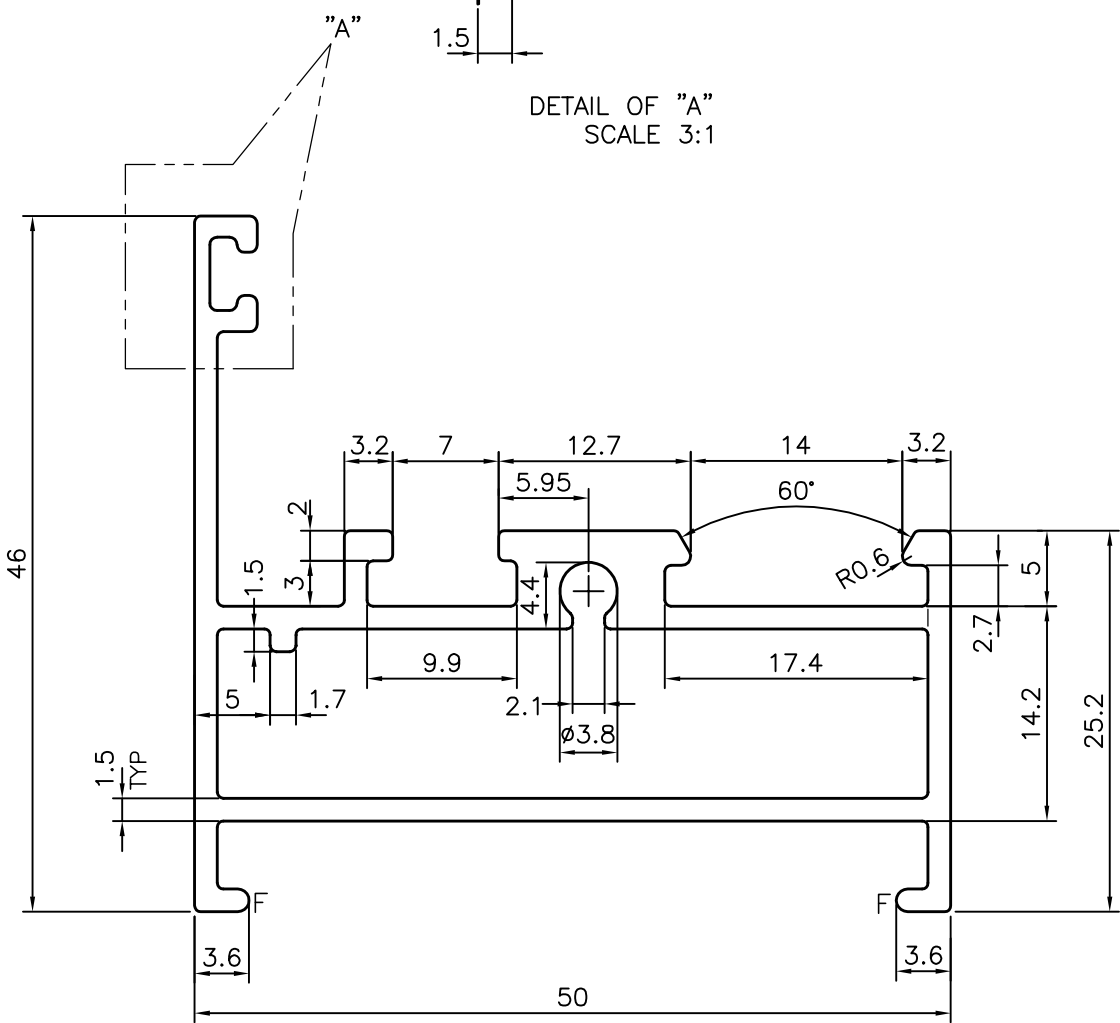

F = FULL RADIUS (2 PLACES)

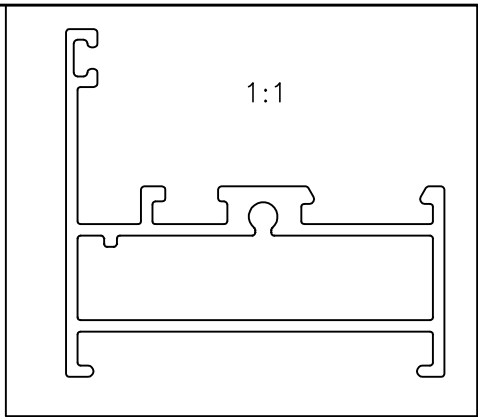
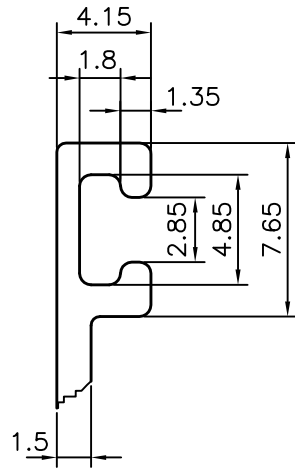

SYMBOL OF QUALITY
AN ISO 9001 COMPANY

JINDAL ALUMINIUM LTD.
BANGALORE-560073 (INDIA)

	NAME	DATE
DRAWN	J.P.KAUSHIK	11-08-2014
CHECKED		
APPROVED	S.S.GARG	13-08-2014
SCALE		2:1
AREA	mm ²	319.762
PERIMETER	mm.	261.115
WEIGHT	kg/m	0.863
DRAWING No.	SECTION No.	
P-13839-1	-	
21510	21510	

1. ALL DIMENSIONS ARE IN mm. 2. ROUND OFF ALL SHARP CORNERS WITH 0.4 mm. 3. TOLERANCES WILL BE AS PER IS:6477-1983, UNLESS OTHERWISE SPECIFIED	
PARTY'S NAME	GENERAL CATEGORY, BANGALORE MARKET
PARTY'S DRAWING No.	AS PER DRAWING
ALLOY & TEMPER	HE9 WP
DESCRIPTION	WINDOW SECTION