

P-13840-1

21511

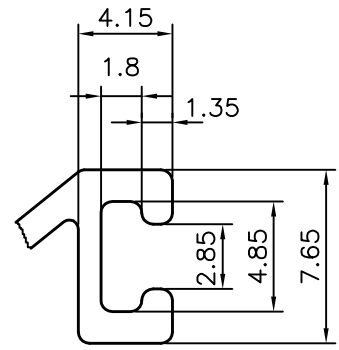

DETAIL OF "A"
SCALE 3:1

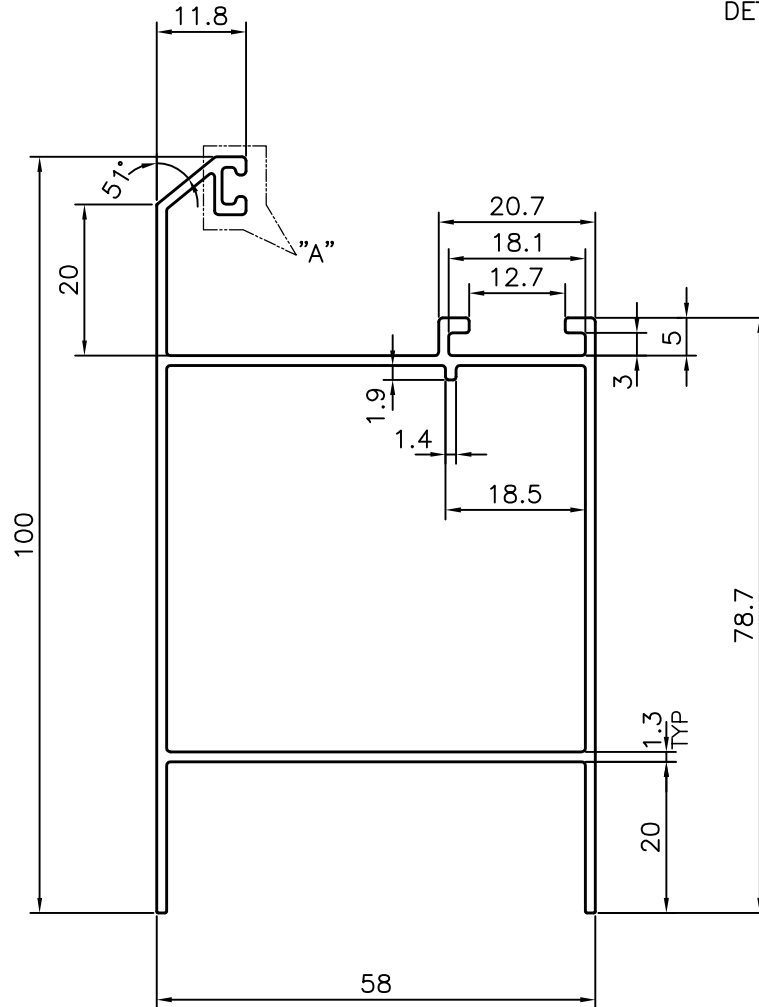

SYMBOL OF QUALITY
AN ISO 9001 COMPANY

JINDAL ALUMINIUM LTD.
BANGALORE-560073 (INDIA)

	NAME	DATE
DRAWN	J.P.KAUSHIK	07-08-2014
CHECKED		
APPROVED	S.S.GARG	13-08-2014

1. ALL DIMENSIONS ARE IN mm.
2. ROUND OFF ALL SHARP CORNERS WITH 0.4 mm.
3. TOLERANCES WILL BE AS PER IS:6477-1983, UNLESS OTHERWISE SPECIFIED

SCALE	1:1
AREA mm ²	418.983
PERIMETER mm.	416.085
WEIGHT kg/m	1.131

PARTY'S NAME	GENERAL CATEGORY, BANGALORE MARKET	DRAWING No.	SECTION No.
PARTY'S DRAWING No.	AS PER DRAWING	P-13840-1	-
ALLOY & TEMPER	HE9 WP	21511	21511
DESCRIPTION	WINDOW SECTION		