

P-11703

S3328

21529

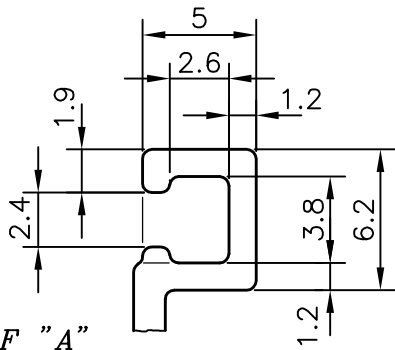

DETAIL OF "A"  
SCALE 3:1

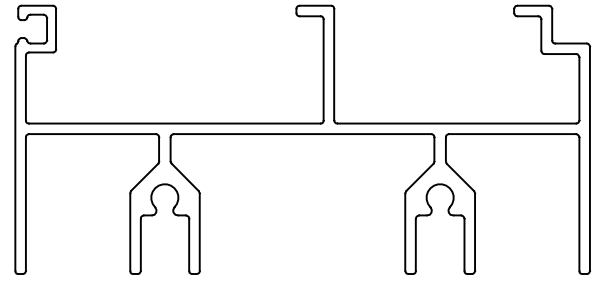

SCALE :- 1:1

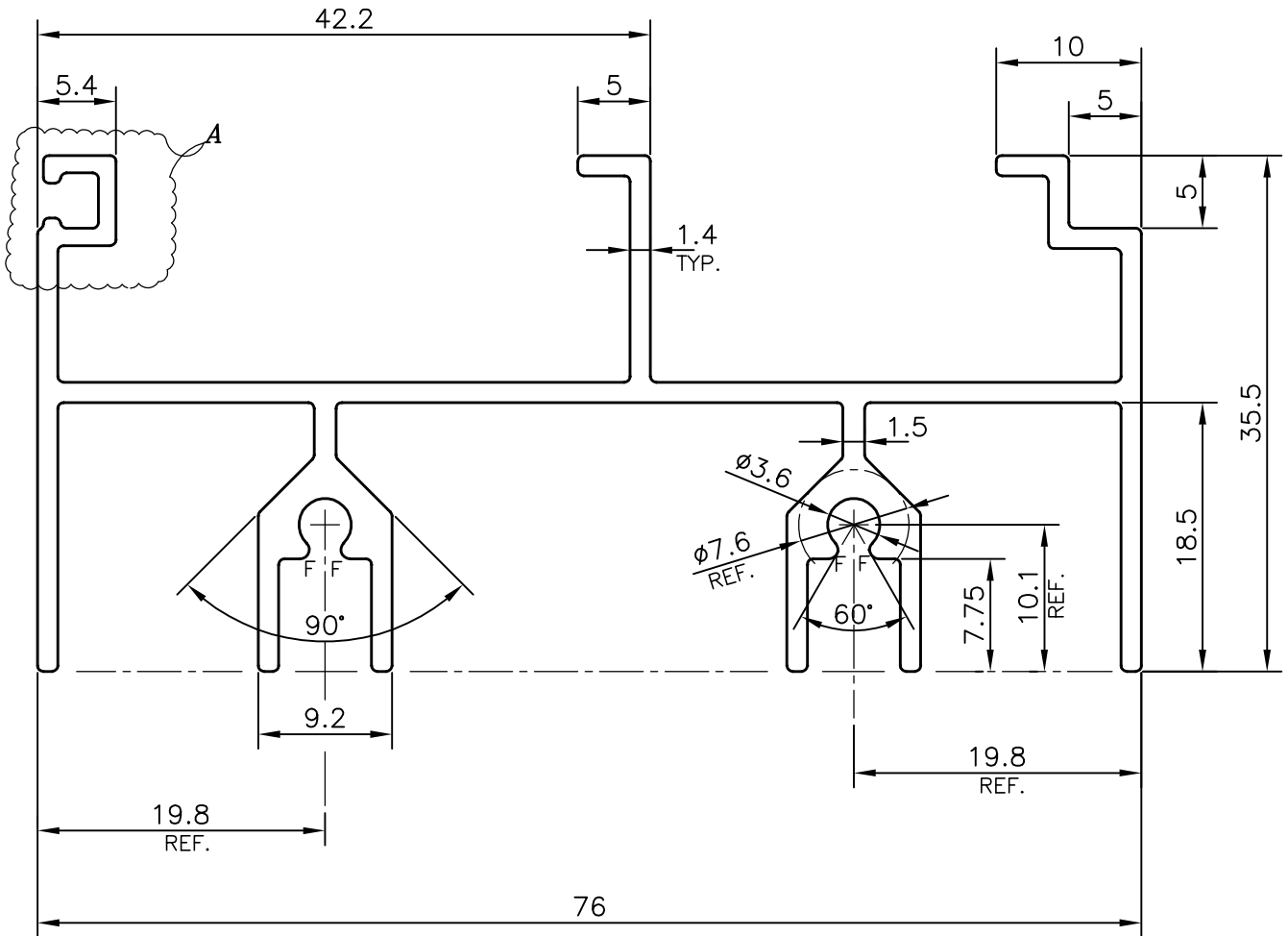

Q71747

F = FULL RADIUS (4 PLACES)



SYMBOL OF QUALITY  
AN ISO 9001 COMPANY

**JINDAL ALUMINIUM LTD.**  
BANGALORE-560073 (INDIA)

	NAME	DATE
DRAWN	PARVESH	24-04-2012
CHECKED		
APPROVED	J.N.RAI	04-06-2012
SCALE		2:1
AREA mm <sup>2</sup>		380.434
PERIMETER mm.		499.039
WEIGHT kg/m		1.027
DRAWING No.	SECTION No.	
P-11703	-	
S3328	S3328	
21529	21529	

1. ALL DIMENSIONS ARE IN mm.
2. ROUND OFF ALL SHARP CORNERS WITH 0.40 mm.
3. TOLERANCES WILL BE AS PER IS:3965-1981, UNLESS OTHERWISE SPECIFIED

PARTY'S NAME SAHARA PRIME CITY LTD., GURGAON

PARTY'S DRAWING No. HT2\*

ALLOY & TEMPER HE9 WP

DESCRIPTION WINDOW SECTION