

P-11754-2
 X1608
 21533

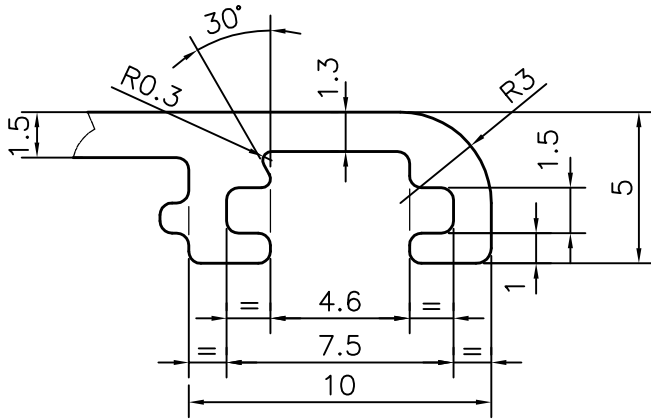

DETAIL OF "A"
 SCALE 4:1

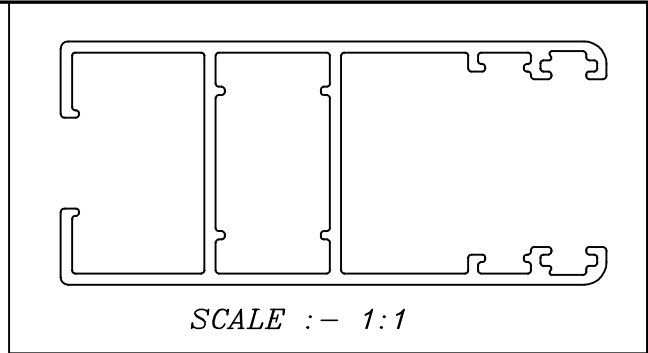

SCALE :- 1:1

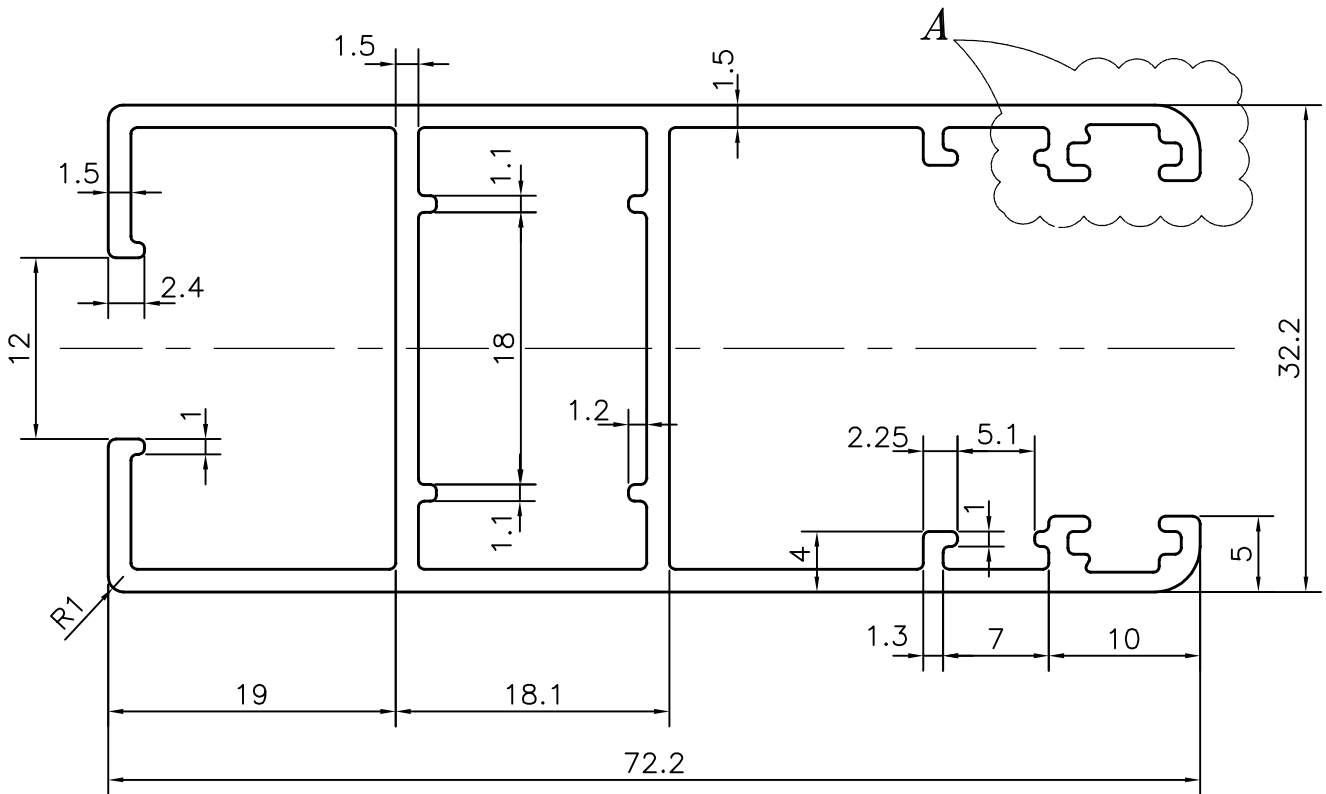

SYMBOL OF QUALITY
 AN ISO 9001 COMPANY

JINDAL ALUMINIUM LTD.
 BANGALORE-560073 (INDIA)

	NAME	DATE
DRAWN	PARVESH	18-05-2012
CHECKED		
APPROVED	S.S.GARG	23-07-2012
SCALE		2:1
AREA mm ²		370.104
PERIMETER mm.		399.207
WEIGHT kg/m		0.999
DRAWING No.	SECTION No.	
P-11754-2	-	
X1608	X1608	
21533	21533	

1. ALL DIMENSIONS ARE IN mm.
2. ROUND OFF ALL SHARP CORNERS WITH 0.40 mm.
3. TOLERANCES WILL BE AS PER IS:6477-1983 , UNLESS OTHERWISE SPECIFIED

PARTY'S NAME	KALPATARU ALUMINIUM PVT. LTD., MUMBAI
PARTY'S DRAWING No.	MODIFIED SECTION No. 21350
ALLOY & TEMPER	HE9 WP
DESCRIPTION	WINDOW SECTION