

P-11831-1
X1606
21534

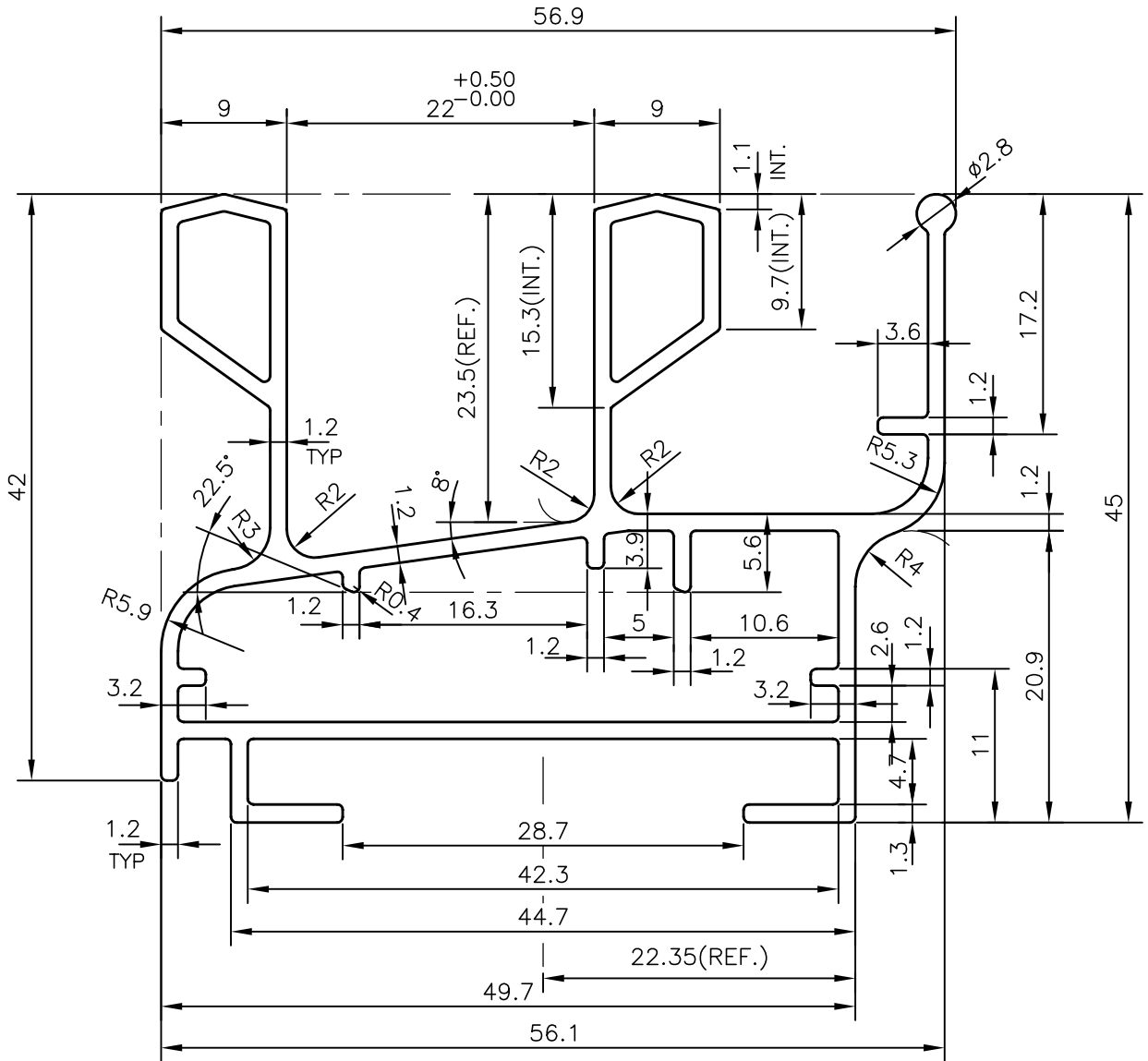
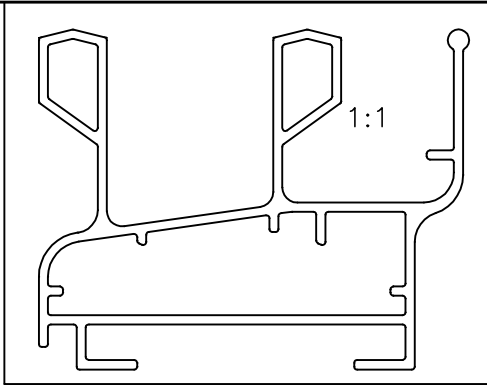

JINDAL ALUMINIUM LTD.
BANGALORE-560073 (INDIA)

	NAME	DATE
DRAWN	J.P.KAUSHIK	19-06-2012
CHECKED		
APPROVED	S.S.GARG	21-06-2012

1. ALL DIMENSIONS ARE IN mm.
2. ROUND OFF ALL SHARP CORNERS WITH 0.40 mm.
3. TOLERANCES WILL BE AS PER IS:6477-1983 UNLESS OTHERWISE SPECIFIED

SCALE	2:1
AREA mm ²	359.85
PERIMETER mm.	355.564
WEIGHT kg/m	0.972

PARTY'S NAME	RIDDHI SIDDHI INNOVATIONS (INDIA) PVT. LTD., JAIPUR
PARTY'S DRAWING No.	cat No.2201
ALLOY & TEMPER	HE9 WP
DESCRIPTION	TWO TRACK SECTION

DRAWING No.	SECTION No.
P-11831-1	-
X1606	X1606
21534	21534