

P-11931-1

S3425

21535

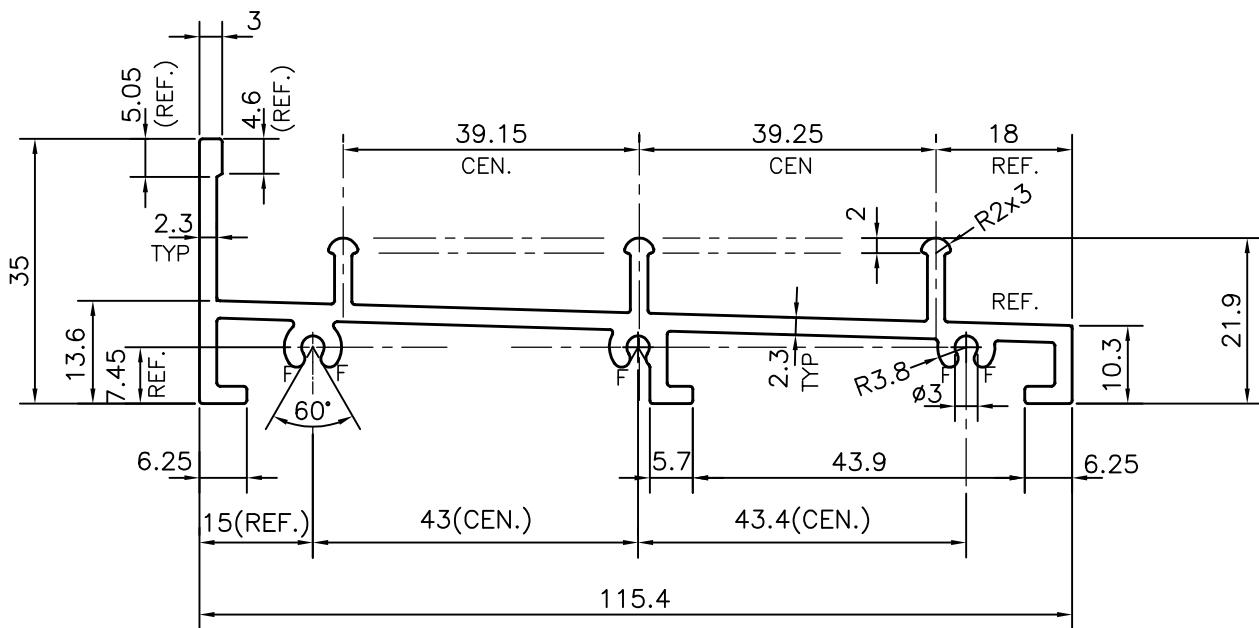

F = FULL RADIUS (5 PLACES)



SYMBOL OF QUALITY
AN ISO 9001 COMPANY

JINDAL ALUMINIUM LTD.
BANGALORE-560073 (INDIA)

	NAME	DATE
DRAWN	J.P.KAUSHIK	30-07-2012
CHECKED		
APPROVED	S.S.GARG	08-08-2012

1. ALL DIMENSIONS ARE IN mm.
2. ROUND OFF ALL SHARP CORNERS WITH 0.40 mm.
3. TOLERANCES WILL BE AS PER,IS:3965-1981 UNLESS OTHERWISE SPECIFIED

SCALE	1:1
AREA mm ²	544.624
PERIMETER mm.	457.258
WEIGHT kg/m	1.470

PARTY'S NAME	SHIV IMPEX, BANGALORE	DRAWING No.	SECTION No.
PARTY'S DRAWING No.	HEAVIER OF SECTION No S3110	P-11931-1	-
ALLOY & TEMPER	HE9 WP	S3425	S3425
		21535	21535
DESCRIPTION	WINDOW SECTION		