

P-11733  
S3322  
21546

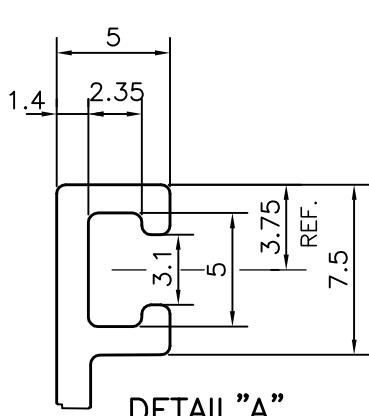

DETAIL "A"  
SCALE 3:1

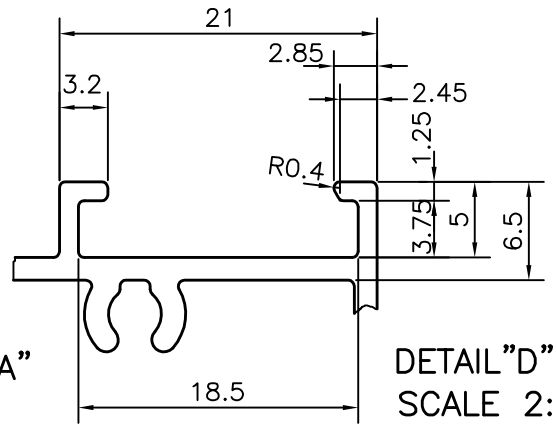

DETAIL "D"  
SCALE 2:1

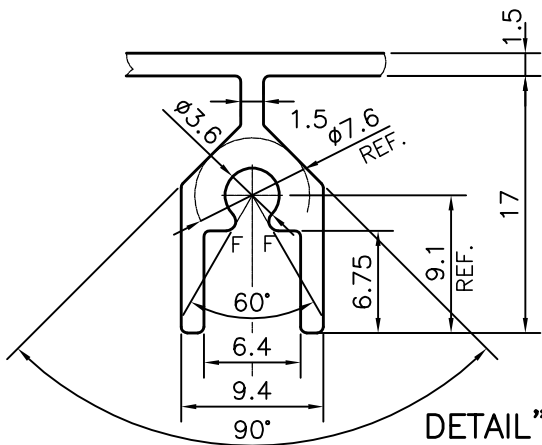
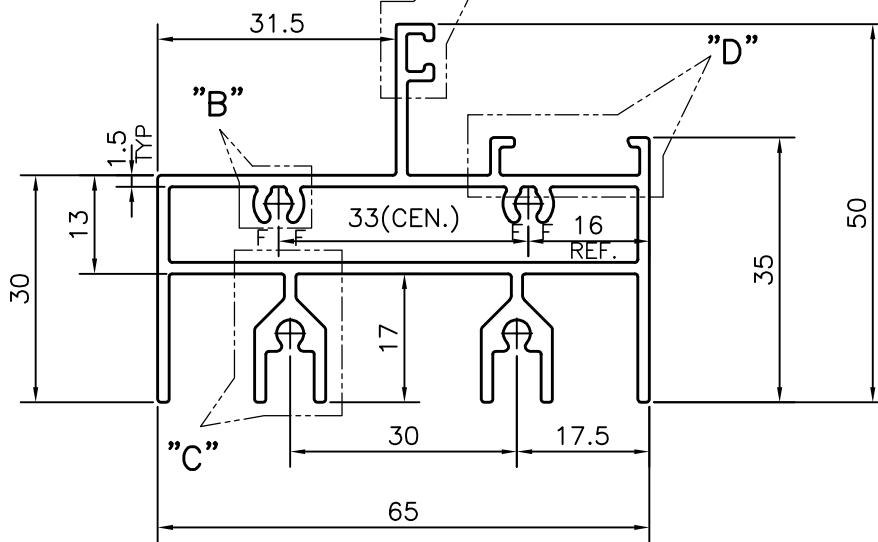

DETAIL "C"  
SCALE 2:1

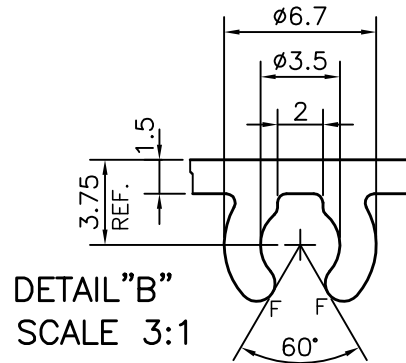

DETAIL "B"  
SCALE 3:1

F = FULL RADIUS (4 PLACES )

Q No:-71885



SYMBOL OF QUALITY  
AN ISO 9001 COMPANY

**JINDAL ALUMINIUM LTD.**  
BANGALORE-560073 (INDIA)

	NAME	DATE
DRAWN	J.P.KAUSHIK	28-04-2012
CHECKED		
APPROVED	J.N.RAI	02-06-2012
SCALE		1:1
AREA mm <sup>2</sup>		492.263
PERIMETER mm.		433.843
WEIGHT kg/m		1.329
DRAWING No.	SECTION No.	
P-11733	-	
S3322	S3322	
21546	21546	

1. ALL DIMENSIONS ARE IN mm.
2. ROUND OFF ALL SHARP CORNERS WITH 0.40 mm.
3. TOLERANCES WILL BE AS PER,IS:6477-1983 UNLESS OTHERWISE SPECIFIED

PARTY'S NAME	SAHARA PRIME CITY LTD., GURGAON
PARTY'S DRAWING No.	HD1
ALLOY & TEMPER	HE9 WP
DESCRIPTION	WINDOW SECTION