

P-11716

S3329

21549

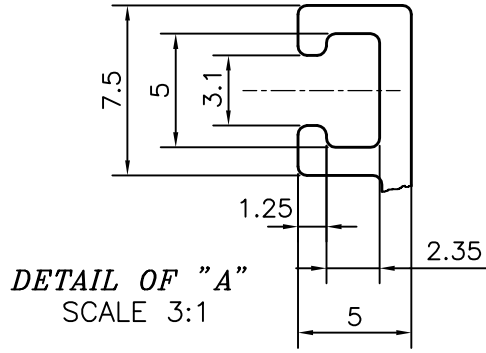
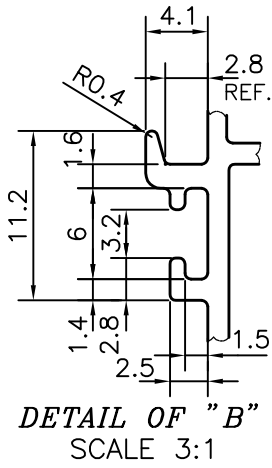
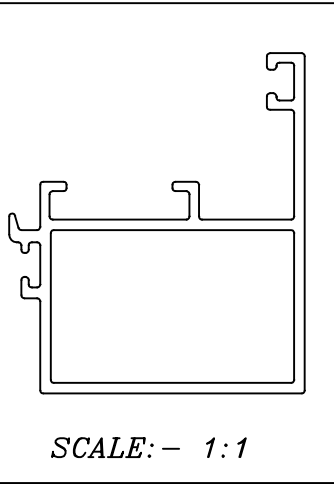
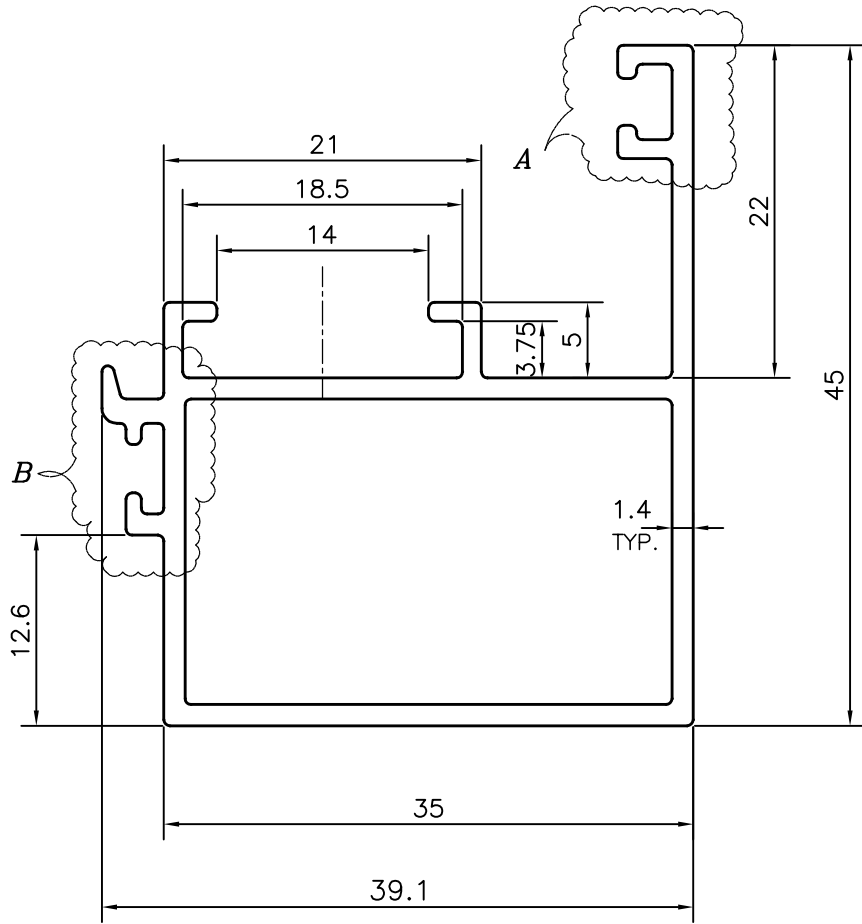

Q71744



SYMBOL OF QUALITY
AN ISO 9001 COMPANY

JINDAL ALUMINIUM LTD.
BANGALORE-560073 (INDIA)

	NAME	DATE
DRAWN	PARVESH	25-04-2012
CHECKED		
APPROVED	J.N.RAI	04-06-2012
SCALE		2:1
AREA	mm ²	229.747
PERIMETER	mm.	222.581
WEIGHT	kg/m	0.620
DRAWING No.	SECTION No.	
P-11716	-	
S3329	S3329	
21549	21549	

1. ALL DIMENSIONS ARE IN mm.
2. ROUND OFF ALL SHARP CORNERS WITH 0.40 mm.
3. TOLERANCES WILL BE AS PER IS:6477-1983, UNLESS OTHERWISE SPECIFIED

PARTY'S NAME	SAHARA PRIME CITY LTD., GURGAON
PARTY'S DRAWING No.	SW9b
ALLOY & TEMPER	HE9 WP
DESCRIPTION	WINDOW SECTION