

P-11722

S3330

21550

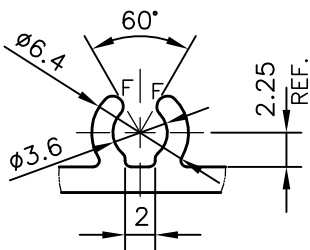
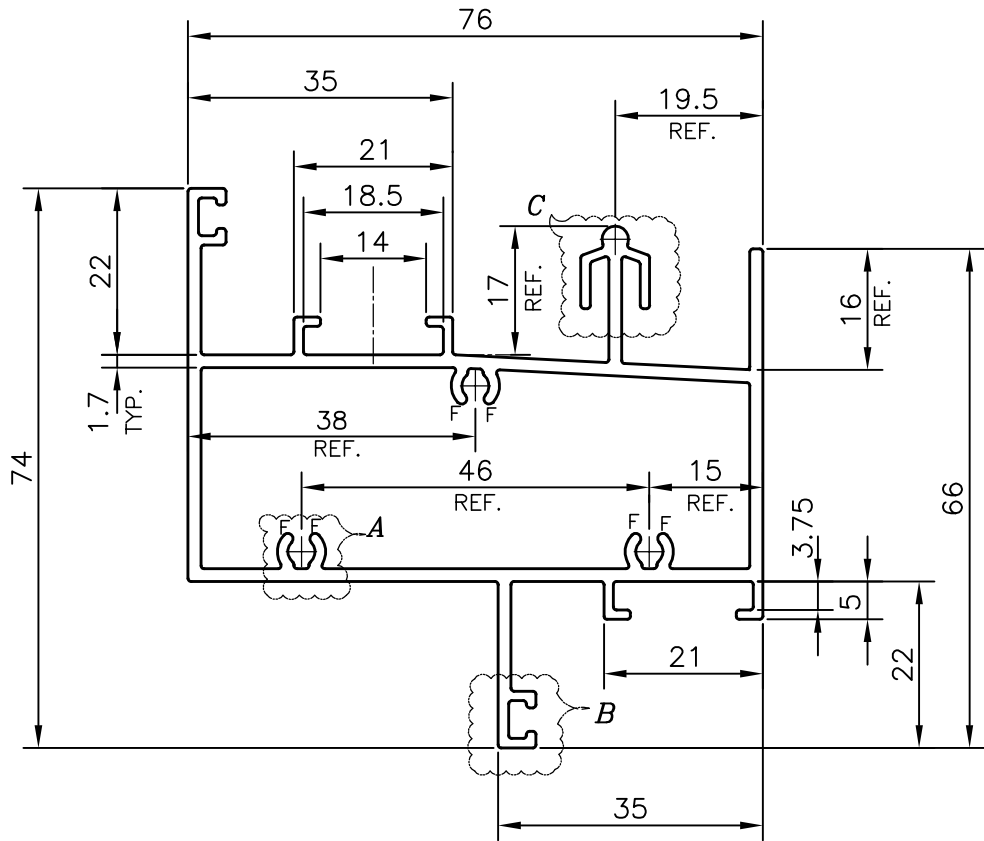

DETAIL OF "A"
SCALE :- 2:1

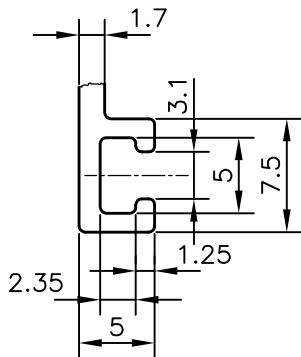

DETAIL OF "B"
SCALE :- 2:1

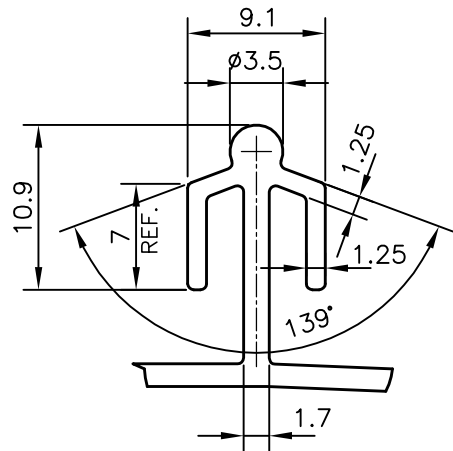

DETAIL OF "C"
SCALE :- 2:1

Q71745

F = FULL RADIUS (6 PLACES)



SYMBOL OF QUALITY
AN ISO 9001 COMPANY

JINDAL ALUMINIUM LTD.
BANGALORE-560073 (INDIA)

	NAME	DATE
DRAWN	PARVESH	27-04-2012
CHECKED		
APPROVED	J.N.RAI	04-06-2012
SCALE		1:1
AREA mm ²		603.246
PERIMETER mm.		486.461
WEIGHT kg/m		1.629
DRAWING No.	SECTION No.	
P-11722	-	
S3330	S3330	
21550	21550	

1. ALL DIMENSIONS ARE IN mm.
2. ROUND OFF ALL SHARP CORNERS WITH 0.40 mm.
3. TOLERANCES WILL BE AS PER IS:6477-1983, UNLESS OTHERWISE SPECIFIED

PARTY'S NAME	SAHARA PRIME CITY LTD., GURGAON
PARTY'S DRAWING No.	SW7b*
ALLOY & TEMPER	HE9 WP
DESCRIPTION	WINDOW SECTION