

P-13976

21555

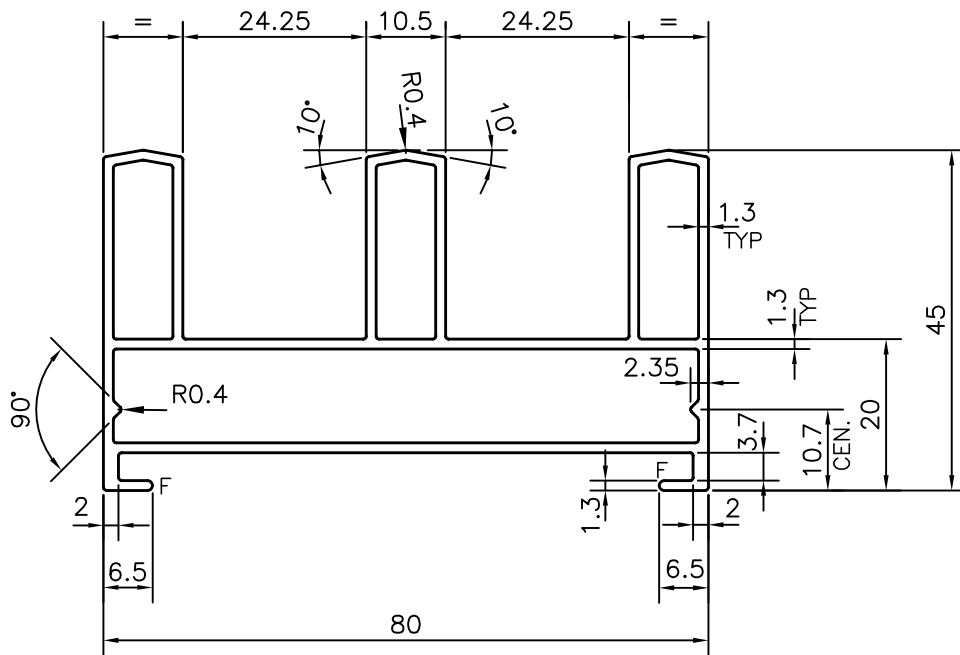

F = FULL RADIUS (2 PLACES)



SYMBOL OF QUALITY
AN ISO 9001 COMPANY

JINDAL ALUMINIUM LTD.
BANGALORE-560073 (INDIA)

	NAME	DATE
DRAWN	J.P.KAUSHIK	09-09-2014
CHECKED		
APPROVED	S.S.GARG	24-09-2014
SCALE		1:1
AREA mm ²		495.034
PERIMETER mm.		369.455
WEIGHT kg/m		1.337
DRAWING No.	SECTION No.	
P-13976	-	
21555	21555	

1. ALL DIMENSIONS ARE IN mm.
2. ROUND OFF ALL SHARP CORNERS WITH 0.40 mm.
3. TOLERANCES WILL BE AS PER,IS:6477-1983 UNLESS OTHERWISE SPECIFIED

PARTY'S NAME	GENERAL CATEGORY, BANGALORE MARKET
PARTY'S DRAWING No.	AS PER DRAWING & REQUIREMENT
ALLOY & TEMPER	HE9 WP
DESCRIPTION	WINDOW SECTION