

P-13818

21557

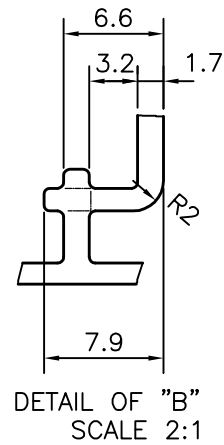
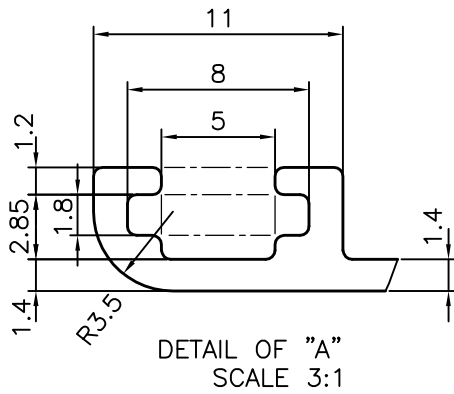
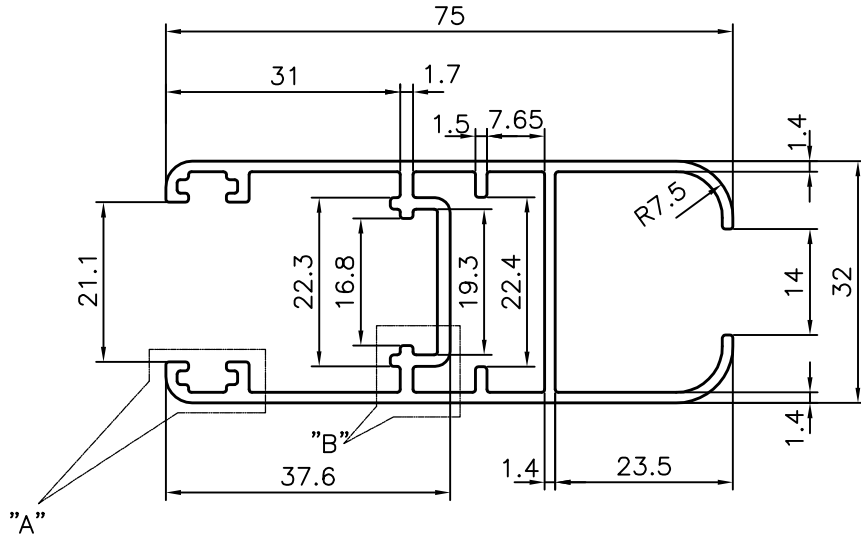

SYMBOL OF QUALITY
AN ISO 9001 COMPANY

JINDAL ALUMINIUM LTD.
BANGALORE-560073 (INDIA)

	NAME	DATE
DRAWN	J.P.KAUSHIK	01-08-2014
CHECKED		
APPROVED	S.S.GARG	16-10-2014
SCALE		1:1
AREA mm ²		377.641
PERIMETER mm.		393.85
WEIGHT kg/m		1.02
DRAWING No.	SECTION No.	
P-13818	-	
21557	21557	

1. ALL DIMENSIONS ARE IN mm.
2. ROUND OFF ALL SHARP CORNERS WITH 0.40 mm.
3. TOLERANCES WILL BE AS PER IS:6477-1983, UNLESS OTHERWISE SPECIFIED

PARTY'S NAME	GENERAL CATEGORY, (MUMBAI MARKET)
PARTY'S DRAWING No.	AS PER SAMPLE
ALLOY & TEMPER	HE9 WP
DESCRIPTION	WINDOW SECTION