

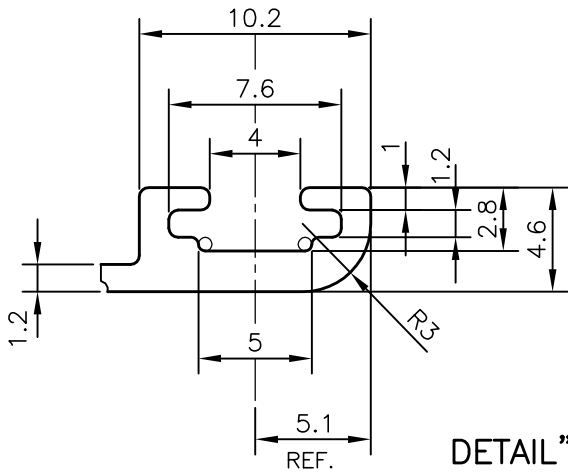

P-11830
X1607
21559

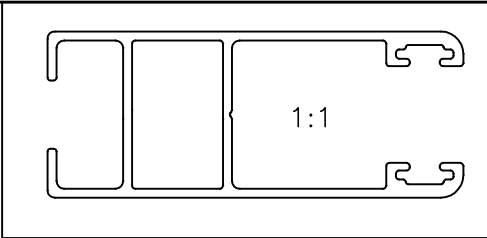

DETAIL "A"
SCALE 3:1

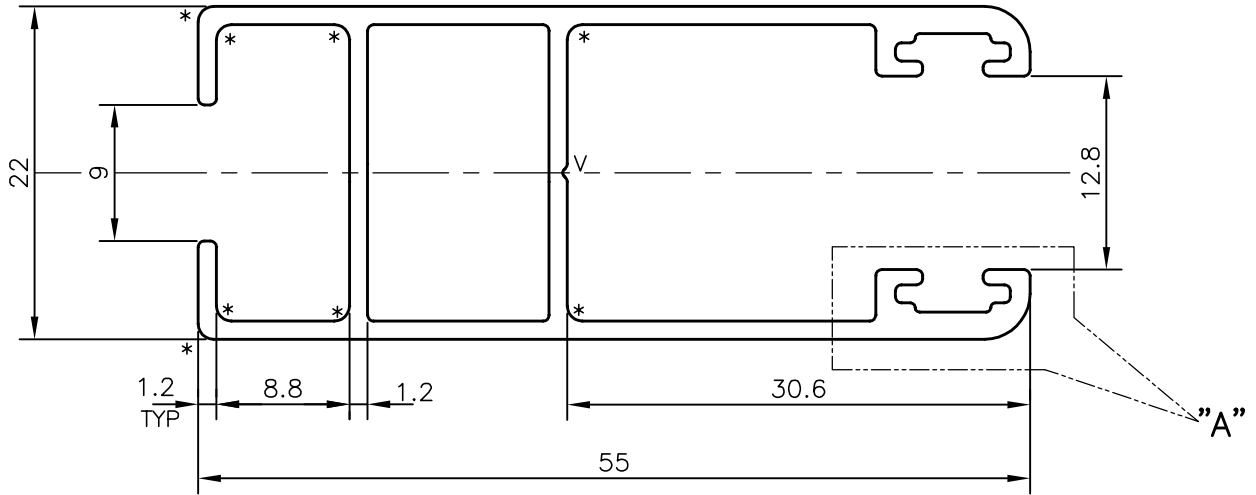

V = V GROOVE 0.3x90°
* = RADIUS 1 (8 PLACES)

 SYMBOL OF QUALITY AN ISO 9001 COMPANY	JINDAL ALUMINIUM LTD. BANGALORE-560073 (INDIA)	NAME		DATE	
		DRAWN	J.P.KAUSHIK	16-06-2012	
1. ALL DIMENSIONS ARE IN mm. 2. ROUND OFF ALL SHARP CORNERS WITH 0.40 mm. 3. TOLERANCES WILL BE AS PER IS:6477-1983 UNLESS OTHERWISE SPECIFIED		CHECKED			
		APPROVED		S.S.GARG	16-07-2012
PARTY'S NAME		RIDDHI SIDDHI INNOVATIONS (INDIA) PVT. LTD., JAIPUR		SCALE	2:1
		PARTY'S DRAWING No. cat No.2206		AREA mm ²	225.639
ALLOY & TEMPER		HE9 WP		PERIMETER mm.	284.286
		DESCRIPTION		SHUTTER SECTION	WEIGHT kg/m
		DRAWING No.		SECTION No.	
		P-11830		-	
		X1607		X1607	
		21559		21559	