

P-11694

S3327

21563

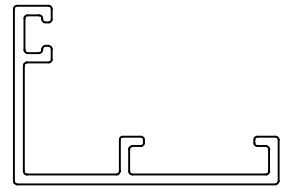

SCALE: - 1:1

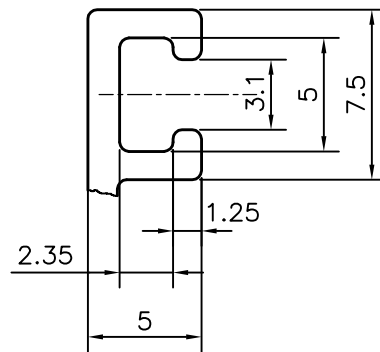
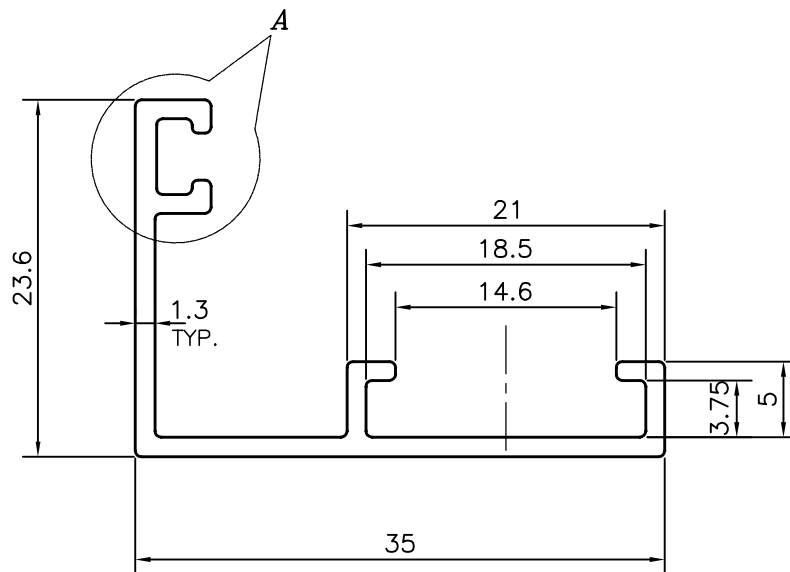

DETAIL OF "A"
SCALE 3:1

Q71750



SYMBOL OF QUALITY
AN ISO 9001 COMPANY

JINDAL ALUMINIUM LTD.
BANGALORE-560073 (INDIA)

	NAME	DATE
DRAWN	PARVESH	23-04-2012
CHECKED		
APPROVED	J.N.RAI	04-06-2012

1. ALL DIMENSIONS ARE IN mm.
2. ROUND OFF ALL SHARP CORNERS WITH 0.40 mm.
3. TOLERANCES WILL BE AS PER IS:3965-1981 , UNLESS OTHERWISE SPECIFIED

SCALE	2:1
AREA mm ²	103.853
PERIMETER mm.	158.936
WEIGHT kg/m	0.28

PARTY'S NAME	SAHARA PRIME CITY LTD., GURGAON
--------------	---------------------------------

PARTY'S DRAWING No.	F8
---------------------	----

ALLOY & TEMPER	HE9 WP
----------------	--------

DESCRIPTION	WINDOW SECTION
-------------	----------------

DRAWING No.	SECTION No.
-------------	-------------

P-11694

-

S3327

S3327

21563

21563