

P-11698
S3338
21565

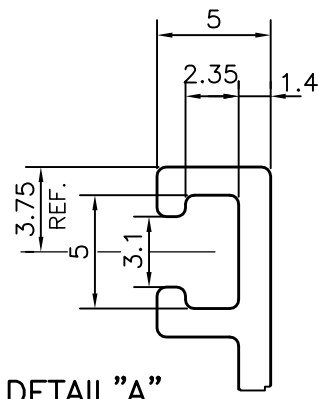

DETAIL "A"  
SCALE 3:1

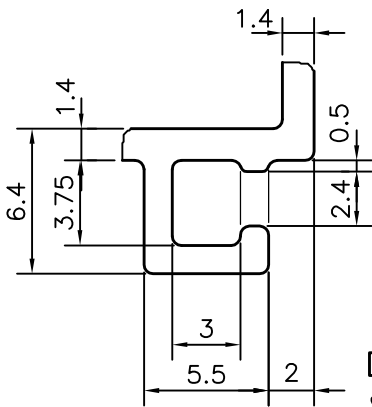
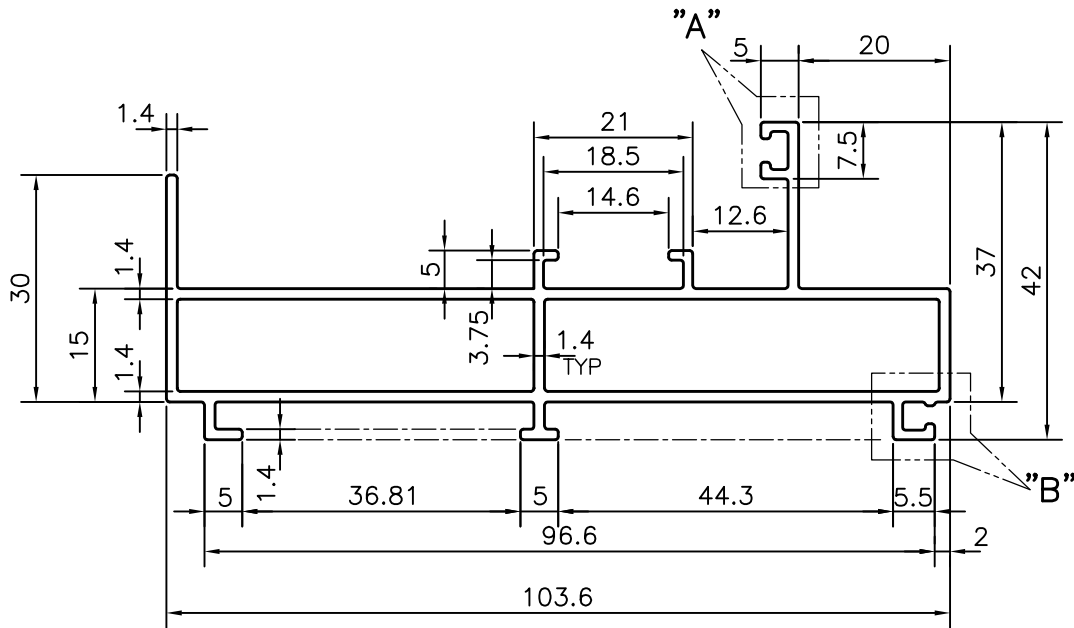

DETAIL "B"  
SCALE 3:1

Q No:-71733

 SYMBOL OF QUALITY AN ISO 9001 COMPANY	<b>JINDAL ALUMINIUM LTD.</b> BANGALORE-560073 (INDIA)	NAME	DATE
		DRAWN	J.P.KAUSHIK
		CHECKED	
		APPROVED	S.S.GARG
		SCALE	1:1
		AREA mm <sup>2</sup>	459.316
		PERIMETER mm.	403.153
		WEIGHT kg/m	1.240
PARTY'S NAME	SAHARA PRIME CITY LTD., GURGAON	DRAWING No.	SECTION No.
PARTY'S DRAWING No.	SD7F	P-11698	-
ALLOY & TEMPER	HE9 WP	S3338	S3338
		21565	21565
DESCRIPTION	WINDOW SECTION		