

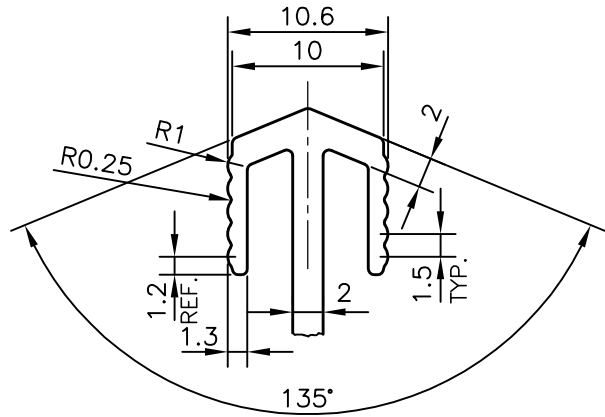

P-11700
S3340
21574

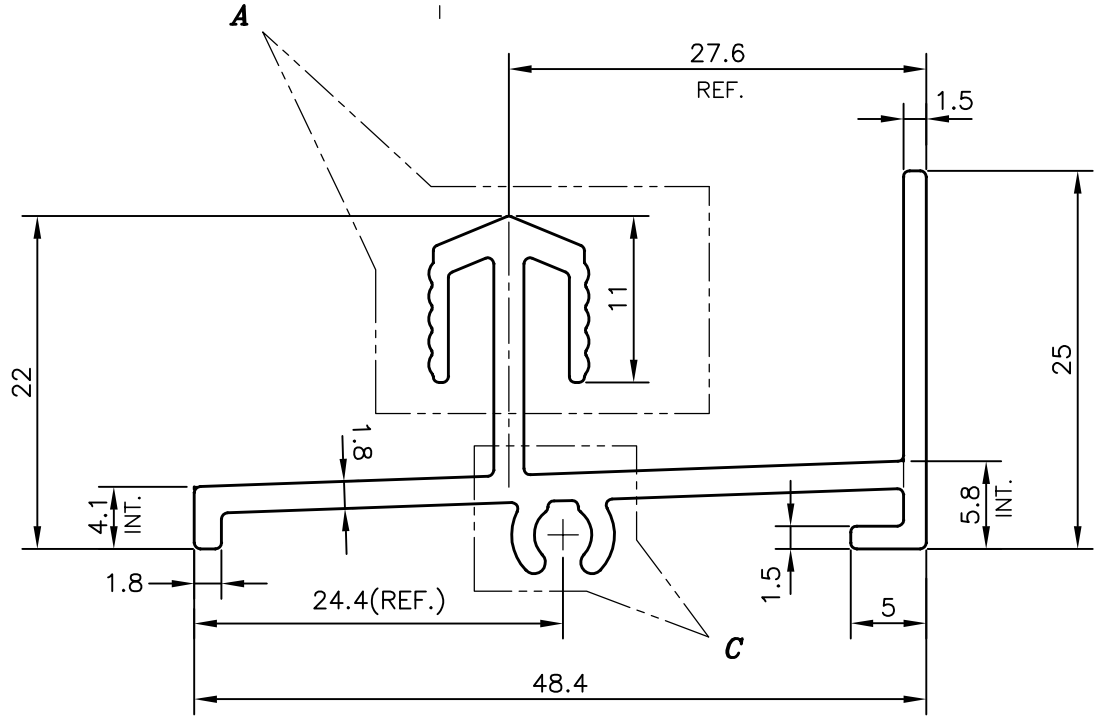
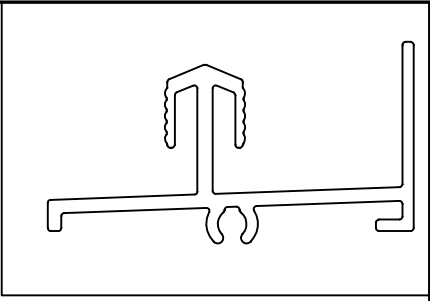
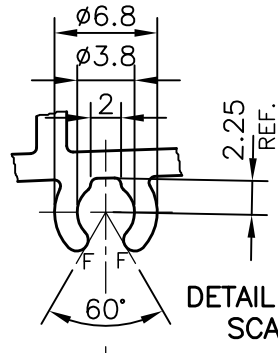

DETAIL OF "A"
SCALE 2:1

F = FULL RADIUS (2 PLACES)

 SYMBOL OF QUALITY AN ISO 9001 COMPANY	JINDAL ALUMINIUM LTD. BANGALORE-560073 (INDIA)	DRAWN	J.P.KAUSHIK	DATE	24-04-2012
		CHECKED			
1. ALL DIMENSIONS ARE IN mm. 2. ROUND OFF ALL SHARP CORNERS WITH 0.40 mm. 3. TOLERANCES WILL BE AS PER IS:3965-1981, UNLESS OTHERWISE SPECIFIED		APPROVED	S.S.GARG		06-06-2012
		SCALE			2:1
PARTY'S NAME SAHARA PRIME CITY LTD., GURGAON		AREA	mm ²		217.426
		PERIMETER	mm.		253.964
PARTY'S DRAWING No. SD1b		WEIGHT	kg/m		0.587
		DRAWING No.		SECTION No.	
ALLOY & TEMPER HE9 WP		P-11700			-
		S3340			S3340
DESCRIPTION WINDOW SECTION		21574			21574