

P-11449-1

S3166

21576

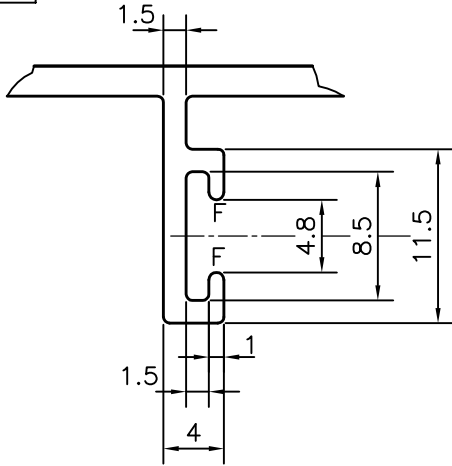

DETAIL OF "B"
SCALE 2:1

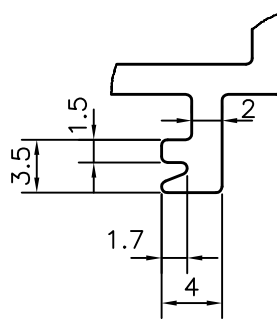

DETAIL OF "C"
SCALE 2:1

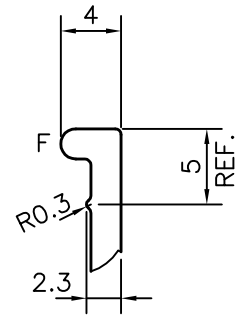

DETAIL OF "A"
SCALE 2:1

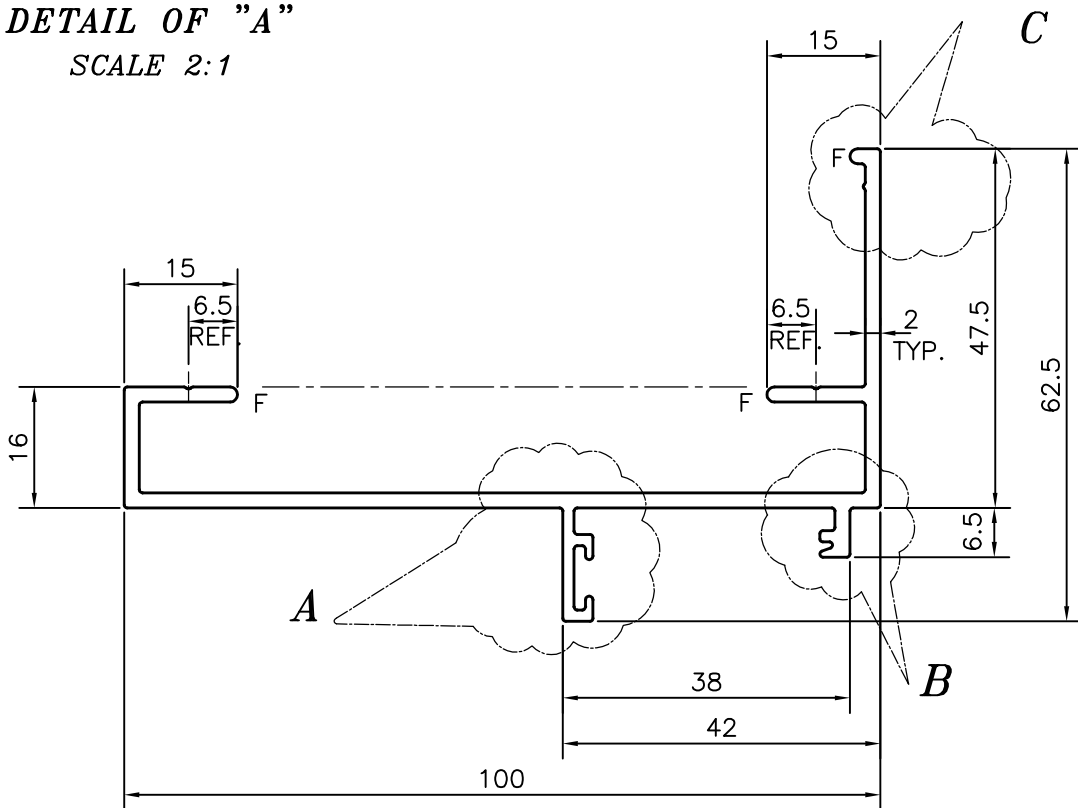

F = FULL RADIUS (5 PLACES)



SYMBOL OF QUALITY
AN ISO 9001 COMPANY

JINDAL ALUMINIUM LTD.
BANGALORE-560073 (INDIA)

	NAME	DATE
DRAWN	PARVESH	23-01-2012
CHECKED		
APPROVED	S.S.GARG	01-02-2012
SCALE		1:1
AREA mm ²		425.531
PERIMETER mm.		438.468
WEIGHT kg/m		1.149
DRAWING No.	SECTION No.	
P-11449-1	-	
S3166	S3166	
21576	21576	

1. ALL DIMENSIONS ARE IN mm. 2. ROUND OFF ALL SHARP CORNERS WITH 0.40 mm. 3. TOLERANCES WILL BE AS PER IS:3965-1981, UNLESS OTHERWISE SPECIFIED	
PARTY'S NAME	NCC URBAN INFRASTRUCTURE LTD., HYDERABAD
PARTY'S DRAWING No.	AS PER DRAWING & SAMPLE
ALLOY & TEMPER	6063 T6
DESCRIPTION	WINDOW SECTION