

P-11450
S3167
21577

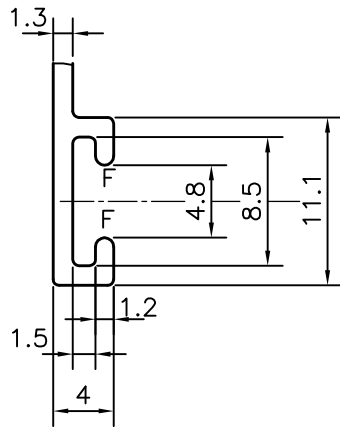

DETAIL OF "A"
SCALE 2:1

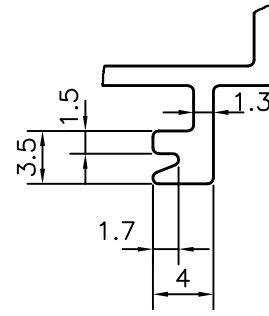

DETAIL OF "B"
SCALE 2:1

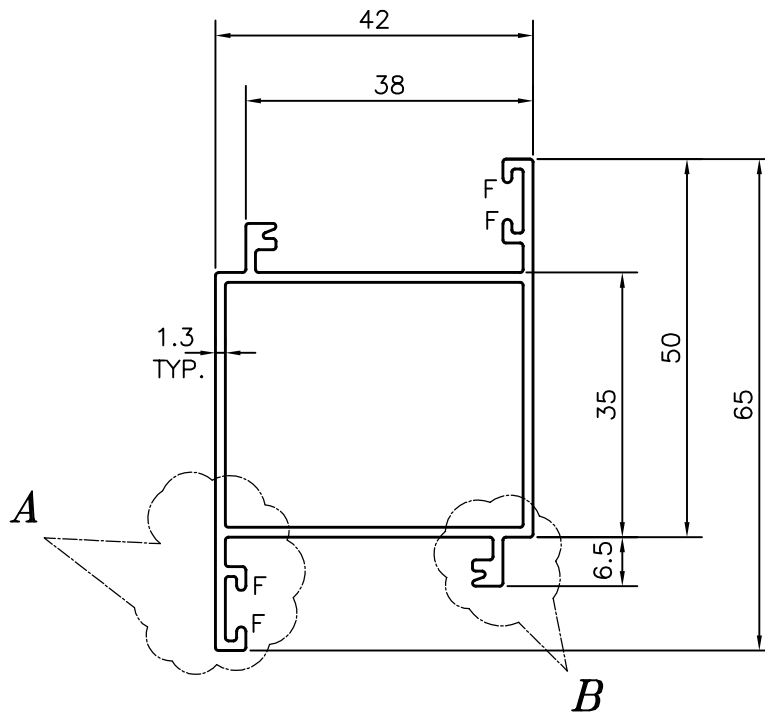

F = FULL RADIUS (4 PLACES)

 SYMBOL OF QUALITY AN ISO 9001 COMPANY	JINDAL ALUMINIUM LTD. BANGALORE-560073 (INDIA)		NAME	DATE
		DRAWN	PARVESH	07-01-2012
		CHECKED		
		APPROVED	S.S.GARG	01-02-2012
1. ALL DIMENSIONS ARE IN mm. 2. ROUND OFF ALL SHARP CORNERS WITH 0.40 mm. 3. TOLERANCES WILL BE AS PER IS:6477-1983, UNLESS OTHERWISE SPECIFIED		SCALE		1:1
		AREA mm ²		287.417
		PERIMETER mm.		284.427
		WEIGHT kg/m		0.776
PARTY'S NAME	NCC URBAN INFRASTRUCTURE LTD., HYDERABAD	DRAWING No.	SECTION No.	
PARTY'S DRAWING No.	AS PER SAMPLE	P-11450	-	
ALLOY & TEMPER	6063 T6	S3167	S3167	
		21577	21577	
DESCRIPTION	WINDOW SECTION			