

P-14271-1

21586

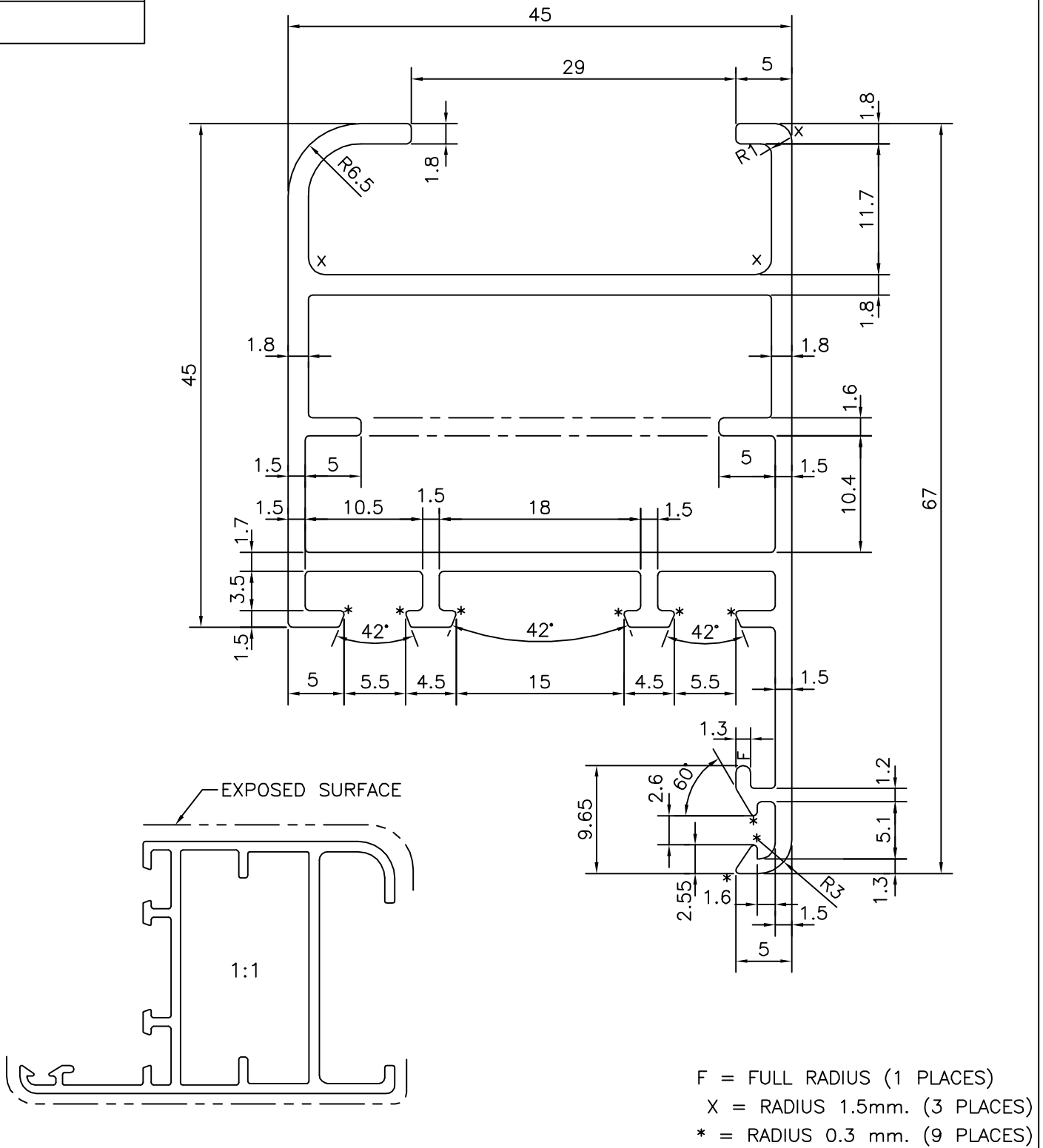

F = FULL RADIUS (1 PLACES)  
 X = RADIUS 1.5mm. (3 PLACES)  
 \* = RADIUS 0.3 mm. (9 PLACES)



SYMBOL OF QUALITY  
 AN ISO 9001 COMPANY

**JINDAL ALUMINIUM LTD.**  
 BANGALORE-560073 (INDIA)

	NAME	DATE
DRAWN	J.P.KAUSHIK	22-12-2014
CHECKED		
APPROVED	S.S.GARG	09-01-2015
SCALE		2:1
AREA mm <sup>2</sup>		408.824
PERIMETER mm.		335.858
WEIGHT kg/m		1.104
DRAWING No.	SECTION No.	
P-14271-1	-	
21586	21586	

1. ALL DIMENSIONS ARE IN mm.
2. ROUND OFF ALL SHARP CORNERS WITH 0.40 mm.
3. TOLERANCES WILL BE AS PER IS:6477-1983 UNLESS OTHERWISE SPECIFIED

PARTY'S NAME	GENERAL CATEGORY, MUMBAI MARKET
PARTY'S DRAWING No.	AS PER DRAWING
ALLOY & TEMPER	6063 T6
DESCRIPTION	WINDOW SECTION