

P-12540

S3675

21593

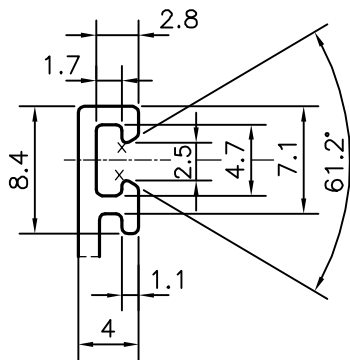
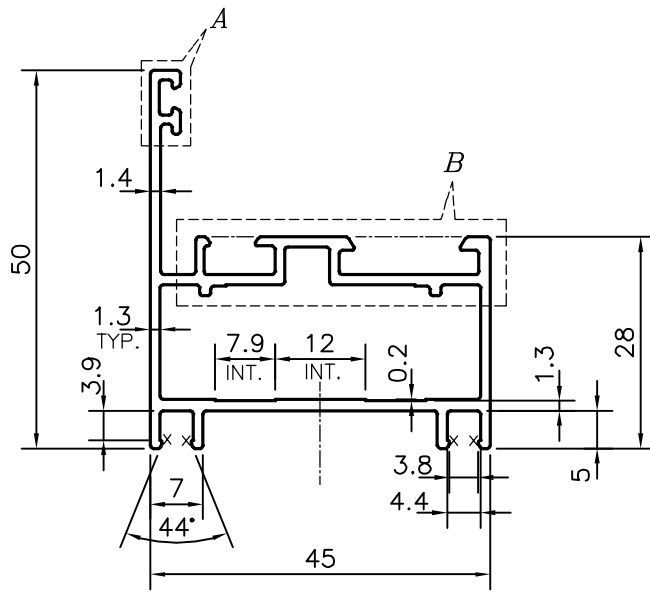

DETAIL OF "A"
SCALE 2:1

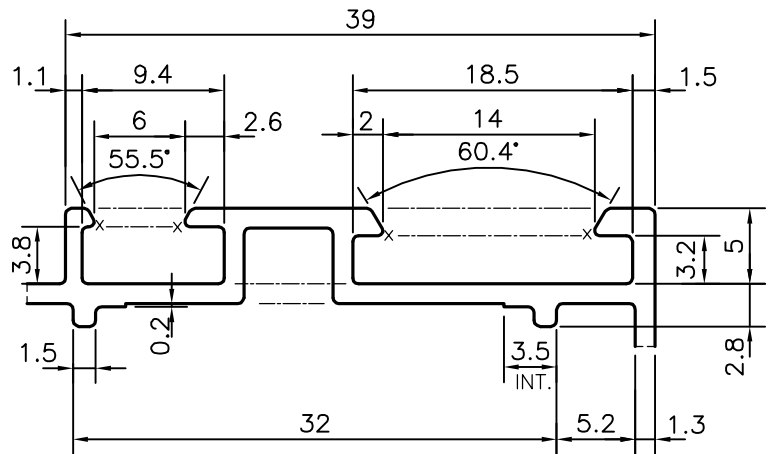

DETAIL OF "B"
SCALE 2:1

X = RADIUS 0.3 mm. (10 PLACES)



SYMBOL OF QUALITY
AN ISO 9001 COMPANY

JINDAL ALUMINIUM LTD.
BANGALORE-560073 (INDIA)

| | NAME | DATE |
|----------|----------|------------|
| DRAWN | PARVESH | 15-02-2013 |
| CHECKED | | |
| APPROVED | S.S.CARG | 27-02-2013 |

1. ALL DIMENSIONS ARE IN mm.
2. ROUND OFF ALL SHARP CORNERS WITH 0.40 mm.
3. TOLERANCES WILL BE AS PER IS:6477-1983 , UNLESS OTHERWISE SPECIFIED

| | |
|----------------------|---------|
| SCALE | 1:1 |
| AREA mm ² | 278.077 |
| PERIMETER mm. | 275.224 |
| WEIGHT kg/m | 0.751 |

| | |
|---------------------|--|
| PARTY'S NAME | HATIM GLAZING & CLADDING PVT. LTD., MUMBAI |
| PARTY'S DRAWING No. | AS PER Auto CAD DRAWING |
| ALLOY & TEMPER | HE9 WP |
| DESCRIPTION | WINDOW SECTION |

| DRAWING No. | SECTION No. |
|-------------|-------------|
| P-12540 | - |
| S3675 | S3675 |
| 21593 | 21593 |