

P-12541

S3676

21594

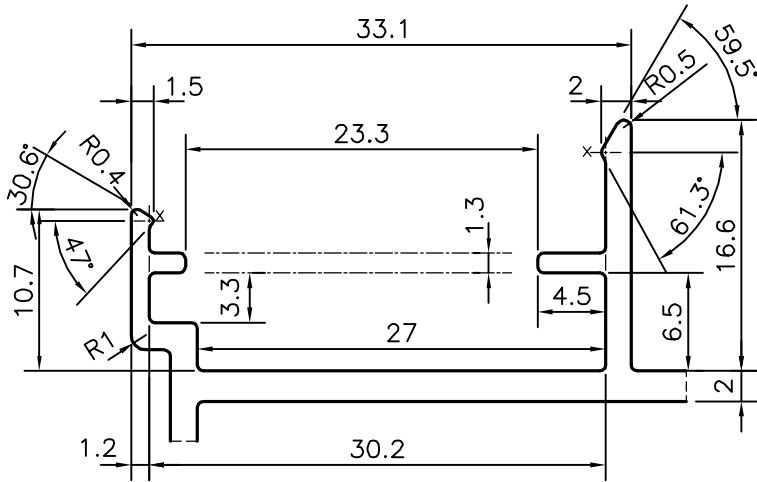
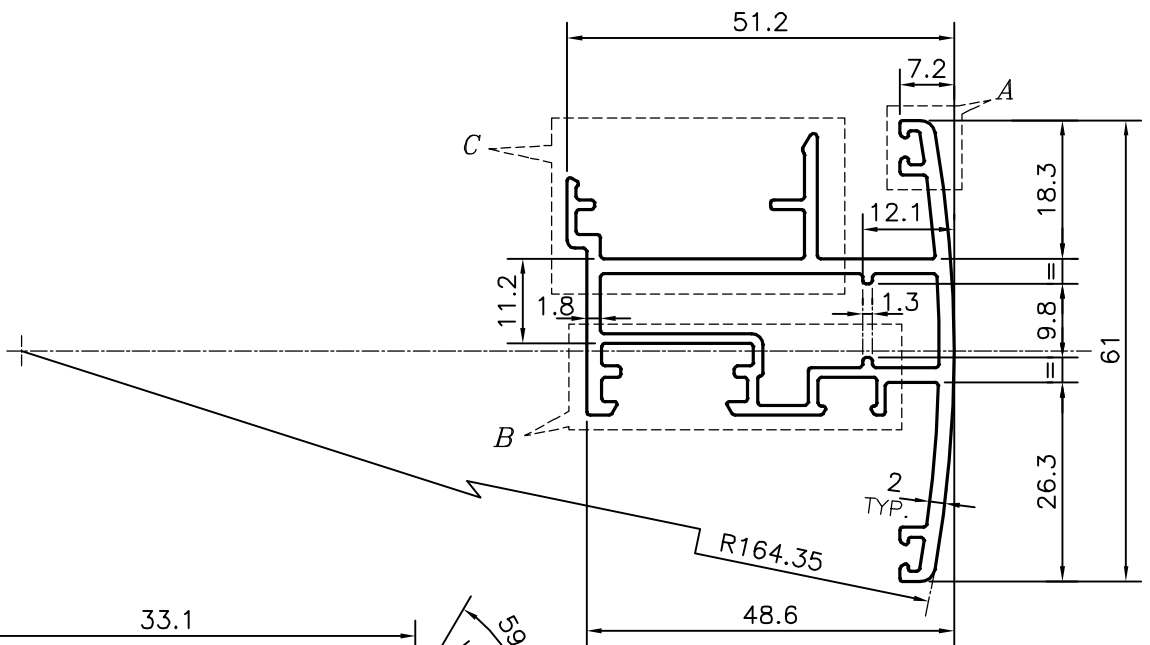

DETAIL OF "C"
SCALE 2:1

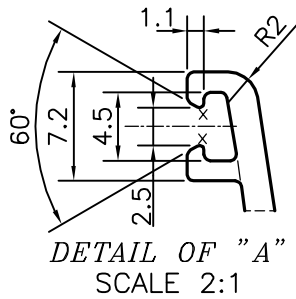

DETAIL OF "A"
SCALE 2:1

X = RADIUS 0.3 mm. (10 PLACES)

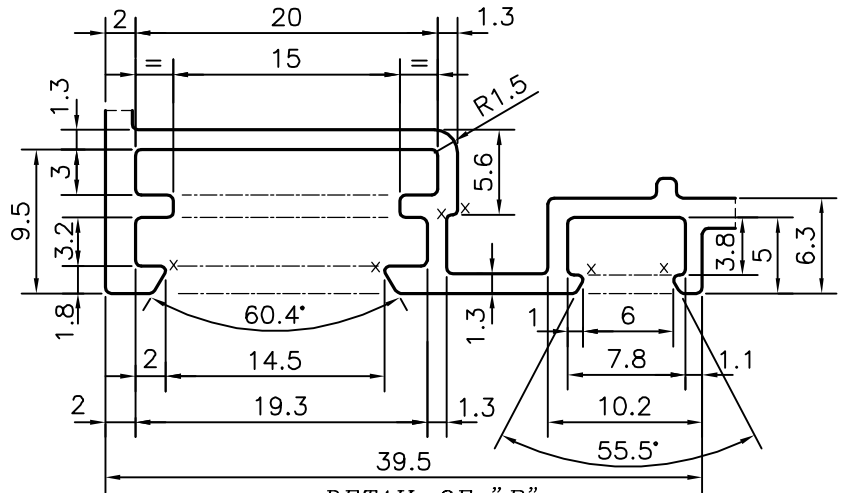

DETAIL OF "B"
SCALE 2:1



SYMBOL OF QUALITY
AN ISO 9001 COMPANY

JINDAL ALUMINIUM LTD.
BANGALORE-560073 (INDIA)

	NAME	DATE
DRAWN	PARVESH	15-02-2013
CHECKED		
APPROVED	S.S.CARG	27-02-2013

1. ALL DIMENSIONS ARE IN mm.
2. ROUND OFF ALL SHARP CORNERS WITH 0.40 mm.
3. TOLERANCES WILL BE AS PER IS:6477-1983 , UNLESS OTHERWISE SPECIFIED

SCALE	1:1
AREA mm ²	433.546
PERIMETER mm.	369.772
WEIGHT kg/m	1.171

PARTY'S NAME	HATIM GLAZING & CLADDING PVT. LTD., MUMBAI
PARTY'S DRAWING No.	AS PER Auto CAD DRAWING
ALLOY & TEMPER	HE9 WP
DESCRIPTION	WINDOW SECTION

DRAWING No.	SECTION No.
P-12541	-
S3676	S3676
21594	21594