

P-12584

S3691

21598

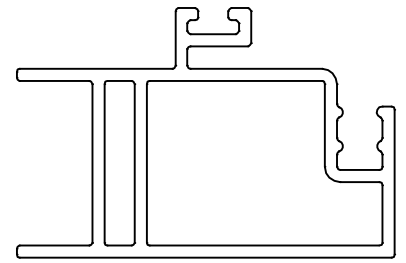

SCALE: - 1:1

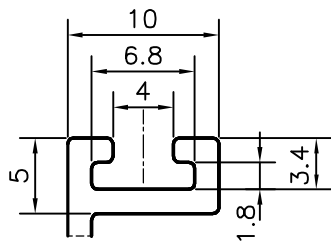
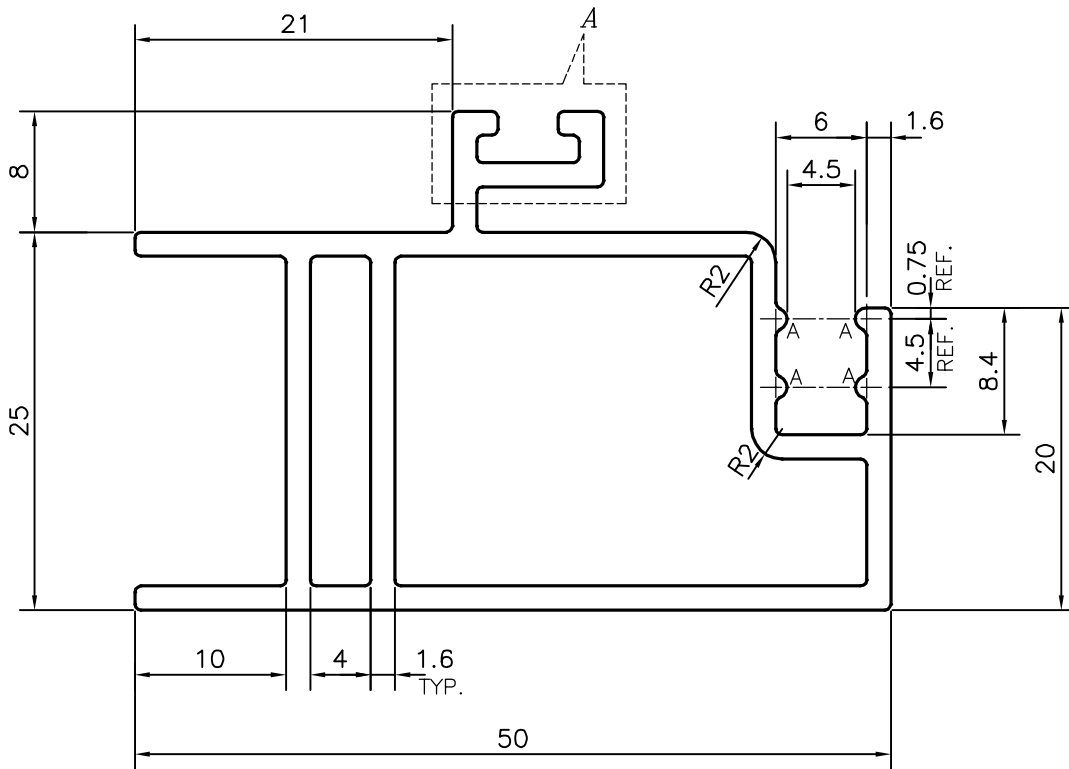

DETAIL OF "A"  
SCALE 2:1

A = RADIUS 0.75 mm. (4 PLACES)



SYMBOL OF QUALITY  
AN ISO 9001 COMPANY

**JINDAL ALUMINIUM LTD.**  
BANGALORE-560073 (INDIA)

	NAME	DATE
DRAWN	PARVESH	06-03-2013
CHECKED		
APPROVED	S.S.GARG	14-03-2013
SCALE		2:1
AREA mm <sup>2</sup>		316.427
PERIMETER mm.		229.687
WEIGHT kg/m		0.854
DRAWING No.	SECTION No.	
P-12584	-	
S3691	S3691	
21598	21598	

1. ALL DIMENSIONS ARE IN mm.
2. ROUND OFF ALL SHARP CORNERS WITH 0.40 mm.
3. TOLERANCES WILL BE AS PER IS:6477-1983 UNLESS OTHERWISE SPECIFIED

PARTY'S NAME	INNOVATIVE INFRA PROJECTS, BANGALORE
PARTY'S DRAWING No.	AS PER DRWING
ALLOY & TEMPER	HE9 WP
DESCRIPTION	FLY SCREEN SECTION