

P-12327-1

S3600

21602

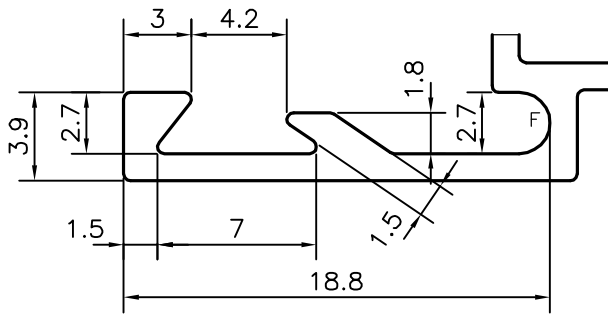

DETAIL OF "A"
SCALE- 3:1

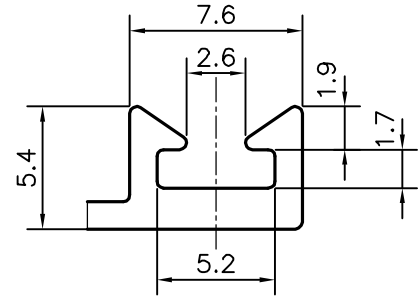

DETAIL OF "B"
SCALE- 3:1

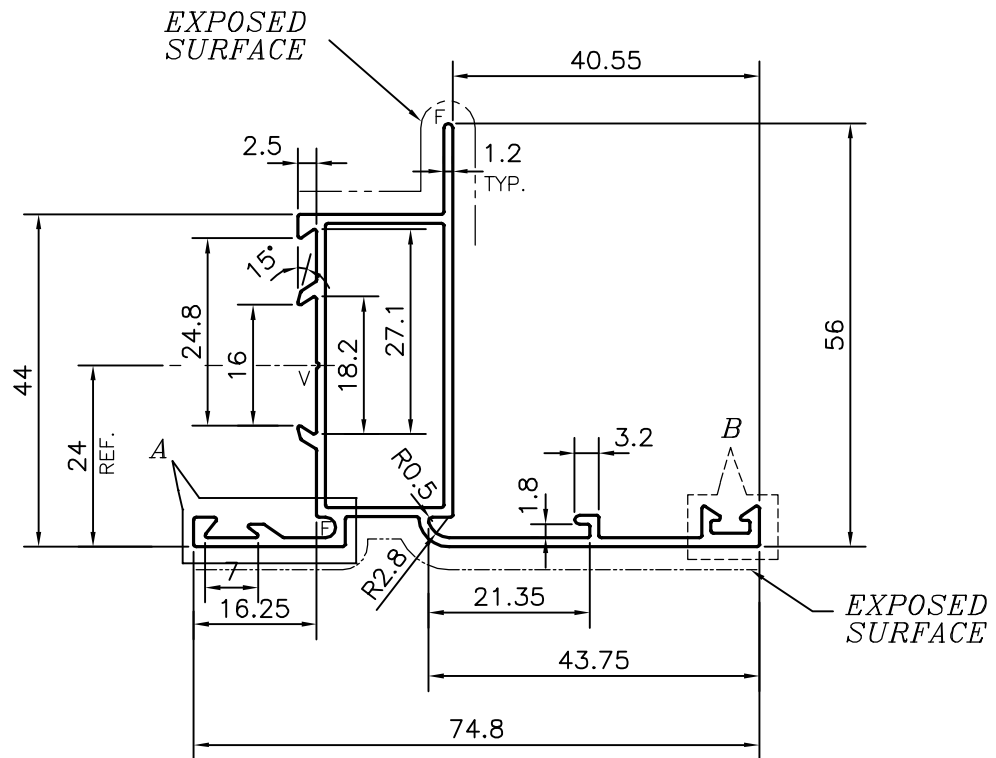

F = FULL RADIUS (2 PLACES)
V = VEE GROOVE 0.3x90° (1 PLACE)



SYMBOL OF QUALITY
AN ISO 9001 COMPANY

JINDAL ALUMINIUM LTD.
BANGALORE-560073 (INDIA)

	NAME	DATE
DRAWN	PARVESH	26-12-2012
CHECKED		
APPROVED	S.S.GARG	10-01-2013
SCALE		1:1
AREA mm ²		278.317
PERIMETER mm.		329.11
WEIGHT kg/m		0.751
DRAWING No.	SECTION No.	
P-12327-1	-	
S3600	S3600	
21602	21602	

1. ALL DIMENSIONS ARE IN mm.
2. ROUND OFF ALL SHARP CORNERS WITH 0.30 mm.
3. TOLERANCES WILL BE AS PER IS:6477-1983 , UNLESS OTHERWISE SPECIFIED

PARTY'S NAME	RBS IMPEX, LUDHIANA
PARTY'S DRAWING No.	VB11552
ALLOY & TEMPER	6060 T6
DESCRIPTION	WINDOW SECTION