

P-12599
S3698
21604

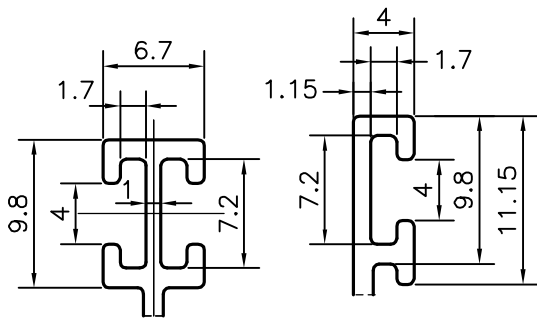

DETAIL OF "A"
SCALE 2:1

DETAIL OF "B"
SCALE 2:1

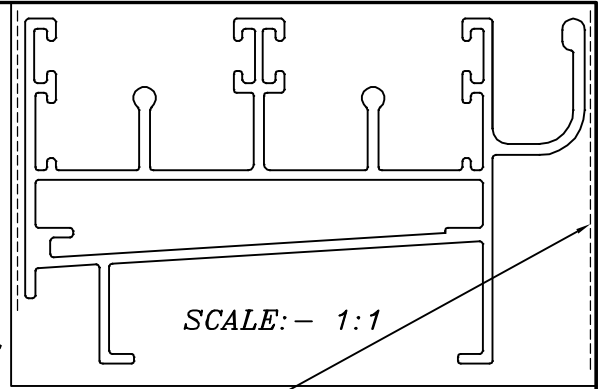

SCALE:- 1:1

EXPOSED SURFACE

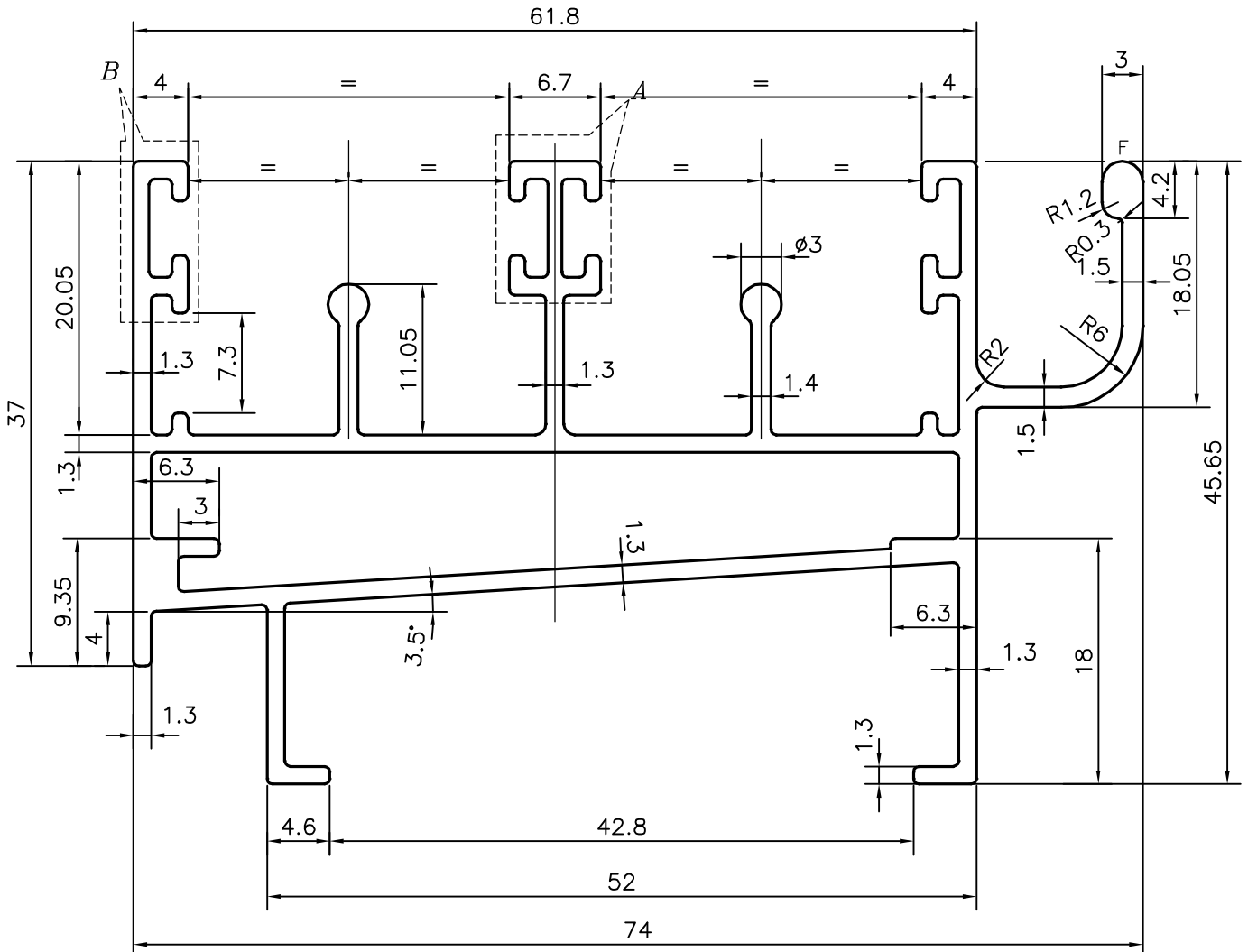

SYMBOL OF QUALITY
AN ISO 9001 COMPANY

JINDAL ALUMINIUM LTD.
BANGALORE-560073 (INDIA)

	NAME	DATE
DRAWN	J.P.KAUSHIK	12-03-2013
CHECKED		
APPROVED	S.S.GARG	18-03-2013
SCALE	2:1	
AREA mm ²	456.224	
PERIMETER mm.	513.07	
WEIGHT kg/m	1.232	
DRAWING No.	SECTION No.	
P-12599	-	
S3698	S3698	
21604	21604	

1. ALL DIMENSIONS ARE IN mm.
2. ROUND OFF ALL SHARP CORNERS WITH 0.50 mm.
3. TOLERANCES WILL BE AS PER IS:6477-1983, UNLESS OTHERWISE SPECIFIED

PARTY'S NAME	ALTRAFAB, BANGALORE
PARTY'S DRAWING No.	AS PER DRAWING
ALLOY & TEMPER	HE9 WP
DESCRIPTION	WINDOW SECTION (2 TRACK BOTTOM)