

P-12096

S3556

21605

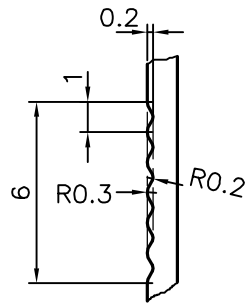

DETAIL "B"
SCALE 4:1

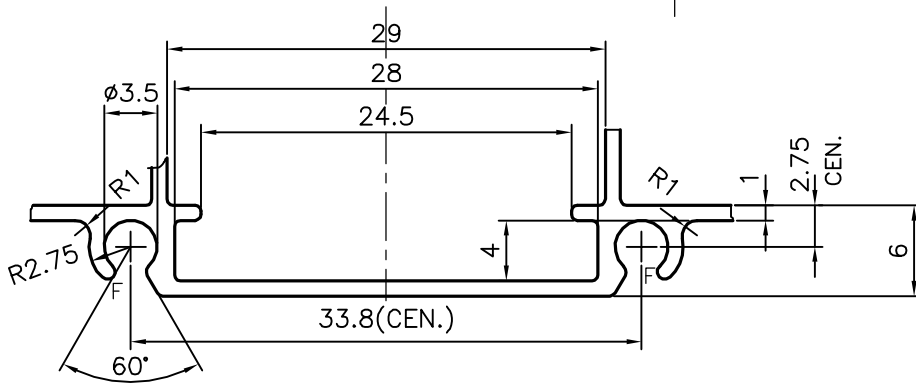
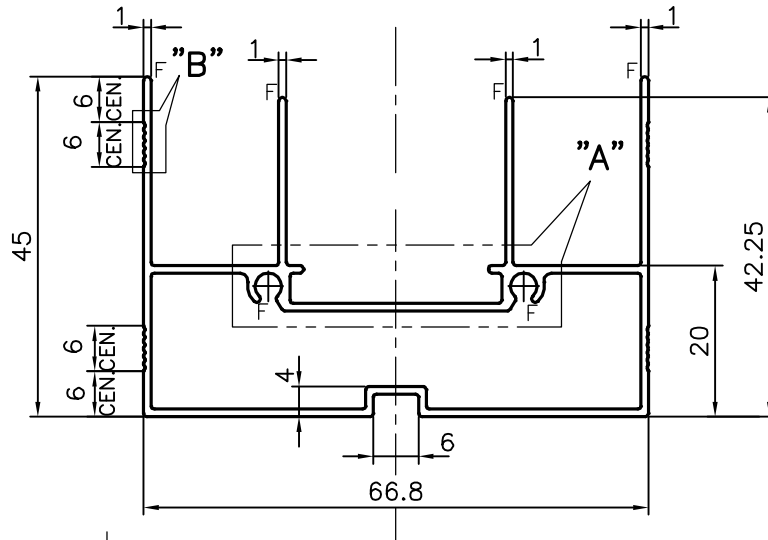

DETAIL "A"
SCALE 2:1

F = FULL RADIUS (6 PLACES)



SYMBOL OF QUALITY
AN ISO 9001 COMPANY

JINDAL ALUMINIUM LTD.
BANGALORE-560073 (INDIA)

	NAME	DATE
DRAWN	J.P.KAUSHIK	03-10-2012
CHECKED		
APPROVED	S.S.GARG	20-11-2012
SCALE		1:1
AREA mm ²		295.48
PERIMETER mm.		382.609
WEIGHT kg/m		0.798
DRAWING No.	SECTION No.	
P-12096	-	
S3556	S3556	
21605	21605	

1. ALL DIMENSIONS ARE IN mm.
2. ROUND OFF ALL SHARP CORNERS WITH 0.40 mm.
3. TOLERANCES WILL BE AS PER,IS:6477-1983 UNLESS OTHERWISE SPECIFIED

PARTY'S NAME	KC WINDOORS (I) PVT.LTD., BANGALORE
PARTY'S DRAWING No.	AS PER SAMPLE
ALLOY & TEMPER	HE9 WP
DESCRIPTION	WINDOW SECTION