

P-12097

S3557

21606

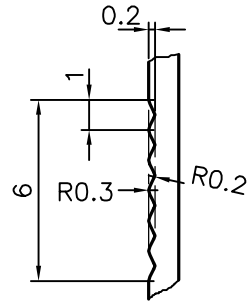

DETAIL "A"
SCALE 4:1

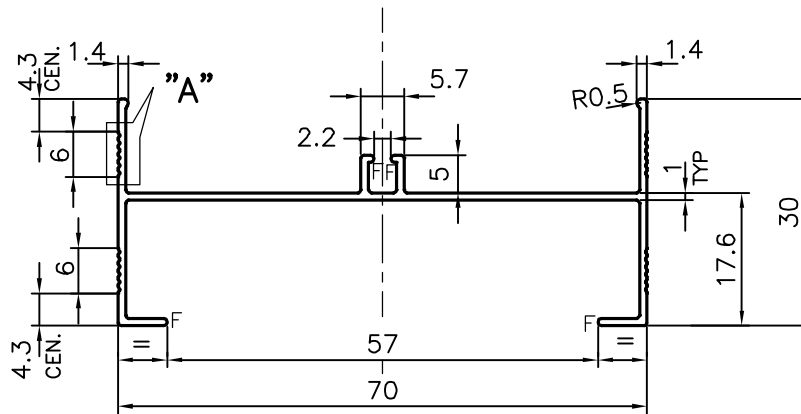

F= FULL RADIUS (4 PLACES)



SYMBOL OF QUALITY
AN ISO 9001 COMPANY

JINDAL ALUMINIUM LTD.
BANGALORE-560073 (INDIA)

	NAME	DATE
DRAWN	J.P.KAUSHIK	03-10-2012
CHECKED		
APPROVED	S.S.GARG	20-11-2012
SCALE		1:1
AREA mm ²		148.522
PERIMETER mm.		301.337
WEIGHT kg/m		0.401
DRAWING No.	SECTION No.	
P-12097	-	
S3557	S3557	
21606	21606	

1. ALL DIMENSIONS ARE IN mm.
2. ROUND OFF ALL SHARP CORNERS WITH 0.40 mm.
3. TOLERANCES WILL BE AS PER, IS:3965-1981 UNLESS OTHERWISE SPECIFIED

PARTY'S NAME	KC WINDOORS (I) PVT.LTD., BANGALORE
PARTY'S DRAWING No.	AS PER SAMPLE
ALLOY & TEMPER	HE9 WP
DESCRIPTION	WINDOW SECTION