

P-12099

S3559

21608

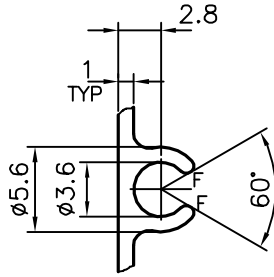
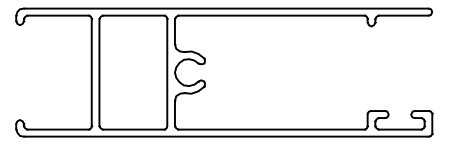

DETAIL "A"  
SCALE 2:1

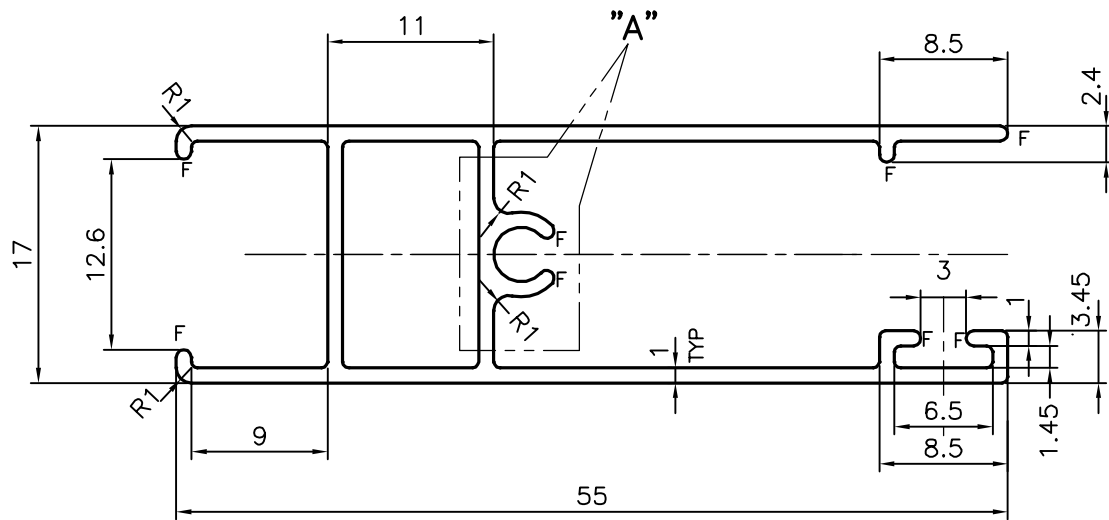

F = FULL RADIUS ( 8 PLACES )



SYMBOL OF QUALITY  
AN ISO 9001 COMPANY

**JINDAL ALUMINIUM LTD.**  
BANGALORE-560073 (INDIA)

	NAME	DATE
DRAWN	J.P.KAUSHIK	03-10-2012
CHECKED		
APPROVED	S.S.GARG	20-11-2012
SCALE		2:1
AREA mm <sup>2</sup>		159.594
PERIMETER mm.		264.358
WEIGHT kg/m		0.431
DRAWING No.	SECTION No.	
P-12099	-	
S3559	S3559	
21608	21608	

1. ALL DIMENSIONS ARE IN mm.
2. ROUND OFF ALL SHARP CORNERS WITH 0.40 mm.
3. TOLERANCES WILL BE AS PER, IS:6477-1983 UNLESS OTHERWISE SPECIFIED

PARTY'S NAME	KC WINDOORS ( I ) PVT.LTD., BANGALORE
PARTY'S DRAWING No.	AS PER SAMPLE
ALLOY & TEMPER	HE9 WP
DESCRIPTION	WINDOW SECTION