

P-12100

S3560

21609

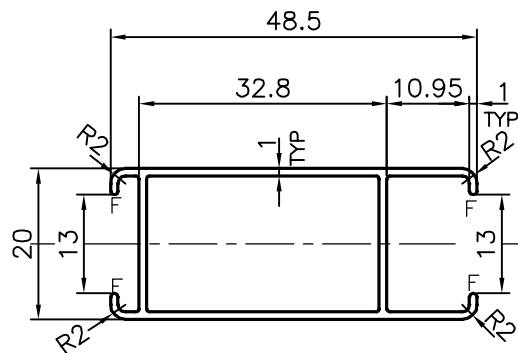

F = FULL RADIUS (4 PLACES)



SYMBOL OF QUALITY
AN ISO 9001 COMPANY

JINDAL ALUMINIUM LTD.
BANGALORE-560073 (INDIA)

	NAME	DATE
DRAWN	J.P.KAUSHIK	03-10-2012
CHECKED		
APPROVED	S.S.GARG	20-11-2012
SCALE		1:1
AREA mm ²		140.27
PERIMETER mm.		180.846
WEIGHT kg/m		0.379
DRAWING No.	SECTION No.	
P-12100	-	
S3560	S3560	
21609	21609	

1. ALL DIMENSIONS ARE IN mm.
2. ROUND OFF ALL SHARP CORNERS WITH 0.40 mm.
3. TOLERANCES WILL BE AS PER, IS:6477-1983 UNLESS OTHERWISE SPECIFIED

PARTY'S NAME KC WINDOORS (I) PVT.LTD., BANGALORE

PARTY'S DRAWING No. AS PER SAMPLE

ALLOY & TEMPER HE9 WP

DESCRIPTION WINDOW SECTION