

P-14506

21616

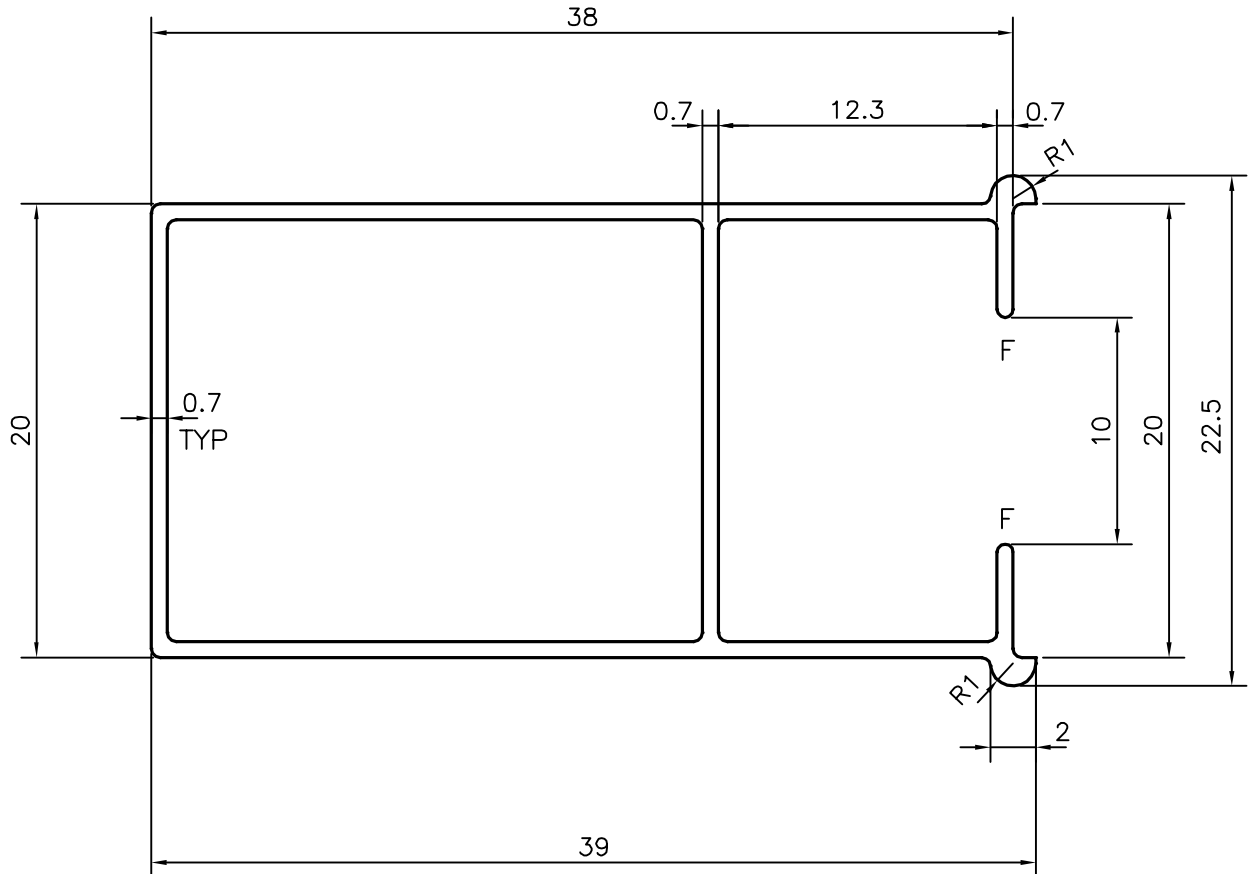

F = FULL RADIUS (2PLACES)

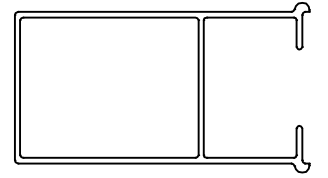

SYMBOL OF QUALITY
AN ISO 9001 COMPANY

JINDAL ALUMINIUM LTD.
BANGALORE-560073 (INDIA)

	NAME	DATE
DRAWN	J.P.KAUSHIK	26-03-2015
CHECKED		
APPROVED	S.S.GARG	09-07-2015
SCALE		3:1
AREA mm ²		89.651
PERIMETER mm.		164.178
WEIGHT kg/m		0.242
DRAWING No.	SECTION No.	
P-14506	-	
21616	21616	

1. ALL DIMENSIONS ARE IN mm.
2. ROUND OFF ALL SHARP CORNERS WITH 0.40 mm.
3. TOLERANCES WILL BE AS PER IS:6477-1983 , UNLESS OTHERWISE SPECIFIED

PARTY'S NAME	GENERAL CATEGORY, COCHIN MARKET
PARTY'S DRAWING No.	AS PER SAMPLE
ALLOY & TEMPER	HE9 WP
DESCRIPTION	WINDOW SECTION